



A Municipal Guidebook for Solar Zoning and Permitting

Zoning and Permitting Solar in Your Municipality



Western Pennsylvania Rooftop Solar Challenge

Solar Installation Guidebook

Prepared for

Citizens for Pennsylvania's Future (PennFuture)
City of Pittsburgh
Allegheny County
Southwestern Pennsylvania Commission
CONNECT (Congress of Neighboring Communities)
SUNWPA (Solar Unified Network of Western Pennsylvania)

Prepared by

Environmental Planning & Design, LLC

December 2012



Acknowledgment: "This material is based upon work supported by the Department of Energy under Award Number DE-EE0005683/000, SunShot Initiative Rooftop Solar Challenge."

Disclaimer: "This report was prepared as an account of work sponsored by an agency of the United States Government. Neither the United States Government nor any agency thereof, nor any of their employees, makes any warranty, express or implied, or assumes any legal liability or responsibility for the accuracy, completeness, or usefulness of any information, apparatus, product, or process disclosed, or represents that its use would not infringe privately owned rights. Reference herein to any specific commercial product, process, or service by trade name, trademark, manufacturer, or otherwise does not necessarily constitute or imply its endorsement, recommendation, or favoring by the United States Government or any agency thereof. The views and opinions of authors expressed herein do not necessarily state or reflect those of the United States Government or any agency thereof."

Acknowledgements

This project was the collaborative effort of many individuals, municipal officials and organizations. We would like to thank the following individuals who dedicated their time and expertise to assist with this project. Their contributions have ensured that these model ordinances and permitting practices have been reviewed through a diverse set of lenses taking into account municipal, legal, engineering, building and electrical code, planning, community and solar industry interests.

Members of our technical advisory committee: Paul Lauer, Kay Pierce, Gordon Israelson, Darrell Rapp, Kevin Flannery, Corey Layman, Brian Temple, Kevin Brett, Ryan Falcone, Joe Morinville, Joe Fucci, Kristin Sullivan.

Stakeholder interviews: Alvin Henderson, Jr., Kay Pierce, Frank Mancini, Jr., Susan Tomazko, Corey Layman, George Totalis, Sherwood Johnson, Joe Ison, Mark Goodman, Joe Morinville, Karen Foltz, Phil Long, Francis Deleonibus, Steven Lane.

Staff from the participating SunShot communities: Ed Warchal, John Barrett, George Zboyovsky, Ralph Costa, Stephen Beuter, Tom Plietz, Bob Caun, Jeffrey Naftal, Mary Ellen Ramage, Terry Huston, Steven Morus, Cindy Simm, Mark Sampogna, Dave Montz, Tricia Levander, Diane Kemp, Mario Leone, Mark Ciufu, Paul Hugus, Andy McWhinney, Rochelle Ogun, Chuck Knaus, Chuck Steinert, Kate Rakus, Jim Sloss, Jason Kambitsis, Andrew Dash, Jeff Walzer, Denise Fitzgerald, Randy Lubin, Bob Fischer, Kevin Creagh, Bob Vita, Jan Barbus, Marie Incorvati, Bill Savatt, Scott Brillhart, Butch Anthony, Brian Kamauf and Sean Gramz.

Our knowledgeable consultants - Andrew Schwartz, Jon Stilan, Jennifer Cristobal, Shari Shapiro, Chuck Means and Bill Brooks.

Staff from the partnering organizations – Jay Rickabaugh, Kathy Risko, Jeaneen Zappa, Zachary Ambrose, Laura Mundell, Jamie Colecchi, Jim Sloss, Hal Saville, Ian Smith, Fred Underwood, Mike Carnahan, Sheila Conry, Daniel Camacho, Adam Rossi, Karen Foltz, Rich Foltz, Eric Casteel, Evan Endres, Jim Price, Sharon Pillar, Heather Sage, Christina Simeone and Courtney Lane.

Participating Municipalities: Aspinwall Borough, Baldwin Borough, Brentwood Borough, Carnegie Borough, City of Pittsburgh, Collier Township, Dormont Borough, Etna Borough, Forest Hills Borough, Greentree Borough, McKees Rocks Borough, Midland Borough, Monaca Borough, Monroeville Borough, Mt. Oliver Borough, O'Hara Township, Richland Township, Scott Township, Shaler Township, Sharpsburg Borough, Stowe Township, Upper St. Clair Township, West Mifflin Borough, Wilkinsburg Borough.



TABLE OF CONTENTS

SECTION A: INTRODUCTION AND BACKGROUND 1

PURPOSE OF THIS GUIDE 2

HOW TO USE THIS GUIDE 3

INTRODUCTION TO SOLAR POWER 4

COMMON MISCONCEPTIONS RELATED TO SOLAR 6

INTERCONNECTIONS.....7

LEGAL CONSIDERATIONS 8

SECTION B: ZONING 11

MODEL ZONING ORDINANCE12

 Section 1. Definitions.13

 Section 2. Purpose.15

 Section 3. Applicability.16

 Section 4. Permitted Zoning Districts.16

 Section 5. Location Within a [Lot/Parcel/Property].17

 Section 6. Design and Installation Standards.17

 Section 7. Setback Requirements.18

 Section 8. Height Restrictions.19

 Section 9. Screening and Visibility.21

 Section 10. Impervious [Lot/Parcel/Property] Coverage Restrictions.24

 Section 11. Non-conformance.25

 Section 12. Signage and/or Graphic Content.28

 Section 13. Performance Requirements.28

 Section 14. Inspection, Safety and Removal.29

 Section 15. Permit Requirements.29

SECTION C: PERMITTING 30

PERMITTING OVERVIEW31

SOLAR PERMIT APPLICATION 33

SUGGESTED PERMIT FEES.....41

SECTION D: APPENDIX

GENERAL INFORMATION

Glossary of Terms

Helpful Contacts, References and Links

PERMIT

Solar PV System Components

Sample Diagrams

Sample Permit

Sample Cut Sheets

ADDITIONAL RESOURCES

Solar Access

Solar and Historic Properties

SECTION A: INTRODUCTION AND BACKGROUND

PURPOSE OF THIS GUIDE

HOW TO USE THIS GUIDE

INTRODUCTION TO SOLAR POWER

COMMON MISCONCEPTIONS RELATED TO SOLAR

INTERCONNECTIONS

LEGAL CONSIDERATIONS



PURPOSE OF THIS GUIDE

The Western Pennsylvania Rooftop Solar Challenge partners, as part of the United States Department of Energy's (DOE) SunShot Initiative, prepared this Guidebook to facilitate successful, cost-effective small scale solar photovoltaic (PV) installations in Western Pennsylvania. Solar energy is an increasingly affordable source of clean, renewable power in this region.

An abundance of information on small scale solar PV installations already exists (see the Appendix for additional resources and links). This Guidebook is not intended to duplicate existing resources for information about residential and commercial small scale solar PV installations (less than 300 kW).

Rather, the purpose of this Guidebook is to introduce basic concepts related to small scale solar PV installations and outline the regulations and permitting process adopted by municipalities participating in the Western Pennsylvania Rooftop Solar Challenge.

Solar Energy

Installation of—and interest in—solar energy installations has been rapidly growing in the United States. The goal of the DOE, through the SunShot Initiative, was to reduce barriers to the installation of small scale solar energy installations and to reduce the cost of producing solar-based energy so that it becomes competitive with fossil fuels.

SunShot Initiative

The DOE's SunShot Initiative was a collaborative nationwide program with a goal to make solar energy cost-competitive with fossil fuels by increasing our national competitiveness in the global solar industry and reducing the non-hardware costs of solar energy projects.

Rooftop Solar Challenge

The Rooftop Solar Challenge was one of the SunShot Initiatives. The DOE found that overly burdensome zoning, permitting and inspection procedures were significant barriers for the installation of solar energy. Twenty-two regional teams throughout the country participated in the Rooftop Solar Challenge to reduce these burdens. Often, inappropriate zoning, fees, and municipal hearings add excessive costs to solar installations and can delay installation, postponing the benefits of the system.

As part of the SunShot Initiative, the Western Pennsylvania Rooftop Solar Challenge Team developed a model solar ordinance, best practices for permitting and inspection and a guidebook for 23 local municipalities in the region.



HOW TO USE THIS GUIDE

This Guidebook contains background information, a model solar zoning ordinance, model permitting application and information related to permitting fees and processes. The appendix contains additional information, a glossary of terms, helpful contact information, and references, and municipal contact information as well as useful examples of completed solar permits.

For municipal staff and officials, this Guidebook serves as an overview of the regulations developed for small scale solar PV systems and the permitting process used to approve those systems. It outlines the criteria needed to help an applicant with the regulatory and permitting process. While the recommendations and models contained in the Guidebook were reviewed by attorneys with experience in municipal law and background in the Pennsylvania Uniform Construction Code, the advice contained herein does not constitute legal advice. Municipalities should have any proposed regulation or permit reviewed by their solicitor.

For homeowners, this Guidebook is intended as a starting point. A home or business owner can use it to gain an understanding of each step in the process of receiving approval for and installing a solar system, understand which steps they can take themselves, and be knowledgeable about where to look for further information or technical assistance.

This Guidebook is not a substitute for professional guidance and should not be the sole resource for technical information. A professional installer should be involved as early as possible and the local municipality should be contacted before a design is completed. Regulations for solar PV installations defer to the provisions in the zoning district of the proposed PV installation and can vary between jurisdictions. Participating municipalities also have flexibility in the adoption of optional provisions, which can impact the final placement and design of a solar PV system.

Rooftop Solar Challenge

Prior to this undertaking, just 22 Pennsylvania municipalities with populations over 2,500 were known to have enacted zoning regulations regarding alternative energy uses. In Southwestern Pennsylvania, most communities did not have any established zoning, permitting or inspection procedures for solar energy. A balanced regulatory approach benefits the industry, the community, residents and business owners by creating appropriate controls for installations while reducing unnecessary restrictions that can hinder the installation of solar energy systems.

The objective of the Rooftop Solar Challenge was to create effective, system specific and uniform zoning, permitting and inspection best practices to: encourage solar energy; minimize barriers to installing solar so as not to improperly interfere with property owners' rights to access solar energy; and comply with existing standards and regulations like the Pennsylvania Municipalities Planning Code, Uniform Construction Code, and National Electric Code to protect the health, safety and welfare of residents, businesses and communities. The Western Pennsylvania Rooftop Solar Challenge addressed small scale solar PV installations (<300 kW).



INTRODUCTION TO SOLAR POWER

Solar PV systems use solar panels to convert sunlight into electricity by using one or more solar panels, a controller or power inverter, interconnections and mounting components. A small solar PV system may provide energy to a single consumer or to an isolated device like a water pump.

Solar PV systems are most commonly installed on roofs, integrated into architecture or ground-mounted on poles or racks.

The Power Grid

The majority of small scale solar PV systems are directly tied to the power grid and do not require battery storage. When the solar PV system power generation exceeds the power needs at a location, the surplus power feeds into the grid. A special utility meter will record power coming in from the utility and power flowing out from the system.

Net Metering

Net metering allows customers to use excess solar electric generation to offset utility-purchased electricity. As the solar PV system generates electricity, it is used to meet the on-site electric demand. If the solar generated electricity exceeds on-site demands, it will feed back to the grid and be credited through a special meter. In Pennsylvania, if a customer generates more electricity than electric usage annually, the customer could receive payment for the surplus at the wholesale rate of electricity.

Participating Municipalities

The Western Pennsylvania Rooftop Solar Challenge Team consisted of seven partner organizations, 21 municipalities in Allegheny County and two municipalities in Beaver County.

The following municipalities participated in this initiative.

Aspinwall Borough
Baldwin Borough
Brentwood Borough
Carnegie Borough
City of Pittsburgh
Collier Township
Dormont Borough
Etna Borough
Forest Hills Borough
Greentree Borough
McKees Rocks Borough
Midland Borough
Monaca Borough
Monroeville Borough
Mt. Oliver Borough
O'Hara Township
Richland Township
Scott Township
Shaler Township
Sharpsburg Borough
Stowe Township
Upper St. Clair Township
West Mifflin Borough
Wilkinsburg Borough

Benefits of Small Scale Solar Systems

The initial investment makes up the majority of the cost of a solar energy system. After paying for the hardware and installation, the solar system generates free energy for 20 to 30 years. Hardware and installation costs have been dropping in recent years due to technological advances, increased market demand and public-sector incentives.

In addition to potential financial benefits, solar energy does not create air or water pollution or greenhouse gases. Solar energy is a renewable resource and works optimally at peak demand times during the year when electricity demand is at its highest.

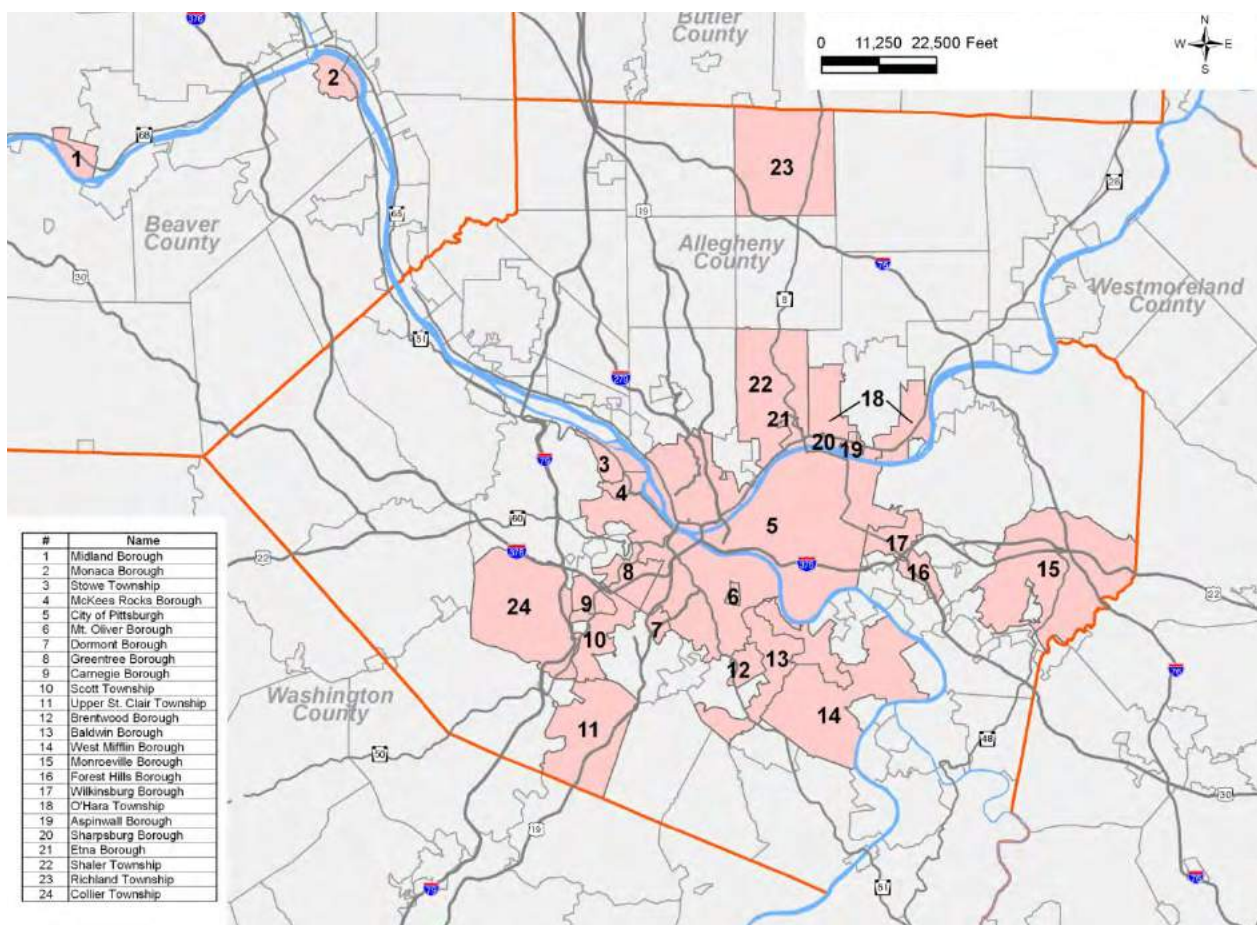

Municipal participation in the Western Pennsylvania Rooftop Solar Challenge



COMMON MISCONCEPTIONS RELATED TO SOLAR

Do the panels cause glare?

Solar panels are engineered to absorb—not reflect—sunlight. A panel with a single layer of anti-reflective coating reflects less than 10% of the sunlight striking it (agricultural vegetation such as corn reflects about 20% of sunlight). Panels are oriented south, facing the sun, resulting in angles of reflection above nearby roads and buildings.

Are the installations noisy?

Most commercial and residential PV systems are stationary so there are no moving parts. However, certain solar PV systems include moving parts that allow panels to follow the sun all day for maximum efficiency. Solar installations, even those with moving parts, operate without producing detectable noise.

Will solar panels harm a roof?

Mounted racking systems typically weigh less than five pounds per square foot. Pennsylvania's standard is that roofs be designed to hold a load of at least 40 pounds per square foot. Therefore, verifying the structural integrity of a roof via engineering approval is unnecessary. Ballasted racking systems will weigh more than five pounds per square foot and are typically used for flat roofs on commercial buildings. Engineering review for commercial roofs is generally recommended.

In Pennsylvania alone, solar installations produce enough energy to power about 17,000 homes. Most of the 6,000 solar systems (165 MW) in the state have been installed since 2008.

Do we get enough sun?

Southwestern Pennsylvania receives significantly more solar radiation than Germany, the leading solar nation in the world with nearly ten percent of its electricity produced by solar. A home in this region can produce the same amount of electricity as a home with solar panels in Arizona by adding an extra panel or two. Temperature levels in the region are optimal for solar PV performance. At temperatures above 75 degrees Fahrenheit, solar PV efficiency levels begin to drop. Many places with a high percentage of cloudless days maintain lower solar PV performance because of high temperatures. Additionally, solar PV installations are able to produce electricity on cloudy days, with only slightly reduced efficiency levels.

Snow rarely interferes with solar production when the panels are in full solar exposure, because snow generally melts quickly. If there is a significant snowfall, the snow may need to be cleaned from the panels for maximum efficiency.



INTERCONNECTIONS

Customers who would like to connect their solar system to the utility grid must meet the specific requirements of the local utility company. These requirements address such issues as grid stability and worker and public safety. The regulations are approved by the Pennsylvania Public Utility Commission.

Customers who wish to interconnect with the grid must complete an application with their local utility. Once the solar system is installed, the utility company will inspect the system to assure that it complies with the state requirements. They will approve the interconnection, if acceptable. A customer is not permitted to send electricity to the grid until this approval is granted.

The municipality is not involved in this process and is not responsible for approving or overseeing interconnection. The customer and installer will communicate directly with the utility and the approval will be issued from the utility to the customer.



LEGAL CONSIDERATIONS

Are solar regulations legal?

The Pennsylvania Municipalities Planning Code (MPC) gives authorization to Pennsylvania municipalities to enact zoning or subdivision and land development controls to regulate solar installations through comprehensive plans and ordinances to regulate the placement, construction, operation and maintenance of alternative energy projects.

The Political Subdivision Tort Claims Act ("PSTCA"), 42 Pa. C.S.A. § 8542, provides that municipalities and their employees are immune from liability except for eight enumerated types of actions such as operation of motor vehicles, the care, custody of controlled personal property, condition of real property, condition of trees, traffic signs, lights and traffic controls, sidewalks, and care, custody or control of animals. None of the categories include actions relating to the issuance of building or zoning permits. Numerous court decisions have held that claims based upon negligent permit issuance are barred by immunity under the PSTCA.

The PSTCA also makes it clear that municipal employees are immune from liability to the same extent for all actions within the scope of the employee's duties (absent willful misconduct). A municipal employee is also entitled to a complete defense and indemnity by the municipality for any action within the scope of the employee's duties (and absent willful misconduct).

The International Building Code and International Fire Code also make it clear that the building code official is not personally liable for decisions within the scope of his/her duties.

Can a solar regulation be challenged in court?

Municipal governments only have the powers that are granted to them by the state legislature. However, this does not limit the ability of municipalities in Pennsylvania to regulate solar facilities, because the ability to regulate these facilities and others is provided in the MPC. In addition, Borough and Township Codes have additional language, outside of the MPC, giving such municipalities broad rights to enact regulations to further the public health, safety and welfare.

Does the Uniform Construction Code apply to solar installations?

Pennsylvania has adopted a state-wide construction code, the Uniform Construction Code (UCC). As of 2009, Pennsylvania adopted versions of the International Residential Code (IRC), the International Building Code (IBC) and the International Mechanical code by reference. In terms of solar, the 2009 IBC and the IRC only address equipment and systems that utilize solar energy for heating and cooling, not PV systems. The 2012 codes include provisions specifically related to PV systems. It is not clear when, if ever, these codes will be adopted by the Pennsylvania legislature.

Are solar installations regulated like other electrical components?

In Pennsylvania, electrical requirements for PV systems are addressed through and specifically regulated by the National Electrical Code, commonly referred to as NFPA 70. Among other issues, the code requires that the roof must be capable of supporting the loads imposed by the PV system, including wind uplift, and that the system complies with the fire classifications for roof coverings.

Why is a solar installation considered an accessory use?

Some municipalities mistakenly regulate small scale residential and commercial solar PV installations as principal uses or conditional uses on a lot—similar to regulations for large scale utility installations for wholesale energy production. When a small scale installation is being used to provide or supplement electricity to a home, business or farm, it should be regulated as an accessory use—similar to a swimming pool, satellite dish, shed or home-based business—because it is a supporting, or accessory, use for the home or business.

Why does a solar installation require a permit?

The UCC does not specifically address solar PV installations and depending on the reading of the code, solar PV systems may or may not require a building permit. However, the regulations circulated by the Department of Labor and Industry under the Pennsylvania Administrative Code regarding utility and miscellaneous use structures appear to require solar PV

systems to comply with the UCC and require building permits for solar PV systems under the UCC.

Under the UCC, building code officials can waive documentation requirements at their discretion. Therefore, because the administration and enforcement of the building codes is done at the municipal level, the decision as to what documentation is required appears to be a municipal one.

Additionally, each municipality is entitled to enact ordinances, including permitting requirements, to structures which are not subject to the UCC. Therefore, even if it is determined that building permits under the UCC are not required for solar PV systems, they may be subject to ordinances and regulations enacted by individual municipalities.

Where can I find solar regulations in my municipality?

Municipalities participating in the Western Pennsylvania Rooftop Solar Challenge incorporated regulations for small scale solar installations as an amendment to their existing zoning ordinances. Including solar PV regulations in the zoning code chapter makes it easier for residents, business owners and industry professionals to navigate the regulatory system and understand what requirements they need to meet.

What if a property has too much shade for solar to work efficiently?

In Pennsylvania, there are no statutes or case law that directly addresses the issue of a neighboring property owner whose trees or buildings cast a shadow interfering with property owner's optimal operation of a solar PV system. However, the general rule that a property owner may build a structure on his property that shades a neighboring property is well established in this state as well as other jurisdictions. It is unlikely that a property owner will have any cause of action against a neighboring property owner for shading a solar energy system.

How can future shade be prevented on a property?

In Pennsylvania, a property owner does not have the right to prevent a neighboring property owner from casting a shadow upon his property, regardless of whether there is any solar energy system in place. The only guaranteed way to ensure access to sunlight across a neighboring property is to create an easement.

An easement may be created between two property owners to prevent one from blocking another's sunlight . These easements are best executed as deed restrictions on the subject properties and not enforced through municipal ordinances.

Where can a solar PV system be installed?

Ground-mounted or freestanding systems are required to comply with minimum yard or setback requirements for accessory structures in the property's zoning district.

Roof-mounted solar PV panels are permitted to slightly exceed the building height limitation for the principal structure. This extra allowance provides for roofs already constructed at the maximum height limit allowed for principal structures. A maximum height limit from the roof is established to limit the height of solar PV panels as well.

"I'd put my money on the sun and solar energy. What a source of power! I hope we don't have to wait until oil and coal run out before we tackle that."

-Thomas Edison

SECTION B: ZONING

MODEL ZONING ORDINANCE

Section 1. Definitions

Section 2. Purpose

Section 3. Applicability

Section 4. Permitted Zoning Districts

Section 5. Location Within a [Lot/Parcel/Property]

Section 6. Design and Installation Standards

Section 7. Setback Requirements

Section 8. Height Restrictions

Section 9. Screening and Visibility

Section 10. Impervious [Lot/Parcel/Property] Coverage Restrictions

Section 11. Non-conformance

Section 12. Signage and/or Graphic Content

Section 13. Performance Requirements

Section 14. Inspection, Safety and Removal

Section 15. Permit Requirements



MODEL ZONING ORDINANCE

The Western Pennsylvania SunShot Rooftop Solar Challenge Team created a model zoning ordinance for adoption by participating municipalities. This model ordinance was developed as an amendment to each municipality's existing zoning ordinance. Regulations for issues like lot setbacks and height restrictions defer to the existing zoning regulations in the applicable district.

Italicized text in brackets, like [*lot/parcel/property*], indicates places where municipal officials have the ability to customize the ordinance prior to adoption to fit existing zoning ordinance language.

Optional parts, indicated by [**bold text**] in brackets, are included to allow customization while maintaining a basic regulatory standard.

This model ordinance was reviewed over several months by municipal staff and elected officials, local and regional organizations as well as legal and planning professionals.

In accordance with Pennsylvania law, applicants whose projects do not meet the provisions of this ordinance always have the option to seek a variance with their individual municipality's Zoning Hearing Board or Zoning Board of Adjustments



Rooftop solar installation. Photo courtesy of energy.gov

WESTERN PENNSYLVANIA ROOFTOP SOLAR CHALLENGE
MODEL ORDINANCE FOR
ON-SITE USAGE OF SOLAR PHOTOVOLTAIC SYSTEMS

[Municipality/Township/Borough] of [Municipality name]
[County], Pennsylvania

Ordinance No. _____

[Effective Date/Date Enacted] _____

An Ordinance to amend the Zoning Ordinance of [Municipality name] by modifying [Article/Section], Definitions, by adding definitions for solar photovoltaic systems and by amending [Article/Section], by incorporating new sections to permit certain solar photovoltaic systems as accessory uses in any zoning district and by revising [Article/Section], by adding provisions for the permitting of certain solar photovoltaic systems.

Municipal Customization

Italic phrases inside brackets, such as [Municipality/Township/Borough], indicate areas where each jurisdiction must fill in specific information, usually related to the name of the municipality.

Other phrases, such as [Article/Section], indicate areas where each municipality must choose the language that matches language in existing codes and regulations that will allow this ordinance to be integrated as an amendment to the existing zoning ordinance.

BE IT HEREBY ENACTED AND ORDAINED by the [Governing body] of [Municipality name], [County], Pennsylvania, that the [Municipal] Zoning Ordinance shall be amended in the following respects:

Section 1. Definitions.

Array: Any number of electrically connected photovoltaic (PV) modules providing a single electrical output.

Building-Integrated System: A solar photovoltaic system that is constructed as an integral part of a principal or accessory building or structure and where the building-integrated system features maintain a uniform profile or surface of vertical walls, window openings, and roofing. Such a system is used in lieu of a separate mechanical device, replacing or substituting for an architectural or structural component of the building or structure that appends or interrupts the uniform surfaces of walls, window openings and roofing. A building-integrated system may occur within vertical facades, replacing view glass, spandrel glass or other facade material; into

semitransparent skylight systems; into roofing systems, replacing traditional roofing materials; or other building or structure envelope systems.

Building-Mounted System: A solar photovoltaic system attached to any part or type of roof on a building or structure that has an occupancy permit on file with the [Municipality/Township/Borough] and that is either the principal structure or an accessory structure on a recorded [lot/parcel/property]. This system also includes any solar-based architectural elements.

Cell: The smallest basic solar electric device which generates electricity when exposed to light.

Drip Line: The outermost edge of a roof including eaves, overhangs and gutters.

Ground-Mounted System: A solar photovoltaic system mounted on a structure, pole or series of poles constructed specifically to support the photovoltaic system and not attached to any other structure.

HVAC: Equipment used to heat, cool or ventilate a structure.

[Optional add-on] *Impervious Surface: A surface area that prevents or retards the infiltration of water into the soil and/or a hard surface area that causes water to run off the surface of the ground in greater quantities or at an increased rate of flow from the conditions prior to development, construction, building or installation.*

Optional Add-On: Impervious Surface

Many municipalities include impervious surface regulations in existing codes and regulations. These municipalities will probably have a definition for impervious surface in their existing zoning ordinance. For municipalities that do not, this definition will be needed as part of the adopted solar ordinance related to Section 10.

Interconnection: The technical and practical link between the solar generator and the grid providing electricity to the greater community.

Kilowatt (kW): A unit of electrical power equal to 1,000 Watts, which constitutes the basic unit of electrical demand. A watt is a metric measurement of power (not energy) and is the rate (not the duration) at which electricity is used. 1,000 kW is equal to 1 megawatt (MW).

Module: A module is the smallest protected assembly of interconnected PV cells.

Net Metering Agreement: An agreement with a local electric utility that allows customers to receive a credit for surplus electricity generated by certain renewable energy systems.

Photovoltaic (PV): A semiconductor based device that converts light directly into electricity.

Solar-Based Architectural Element: Structural/architectural element that provides protection from weather that includes awnings, canopies, porches or sunshades and that is constructed with the primary covering consisting of solar PV modules, and may or may not include additional solar PV related equipment.

Solar Photovoltaic (PV) Related Equipment: Items including a solar photovoltaic cell, panel or array, lines, mounting brackets, framing and foundations used for or intended to be used for collection of solar energy.

Solar Photovoltaic (PV) System: A solar collection system consisting of one or more building- and/or ground-mounted systems, solar photovoltaic cells, panels or arrays and solar related equipment that rely upon solar radiation as an energy source for collection, inversion, storage and distribution of solar energy for electricity generation. A solar PV system is a generation system with a nameplate capacity of not greater than 50 kilowatts if installed at a residential service or not larger than 3,000 kilowatts at other customer service locations and do not produce excess on-site energy greater than currently permitted by Pennsylvania Public Utility Commission guidelines.

Tracking System: A number of photovoltaic modules mounted such that they track the movement of the sun across the sky to maximize energy production, either with a single-axis or dual-axis mechanism.

Unregulated Yard Area: Area not within a building and not in a defined setback or yard area.

Section 2. Purpose.

It is the purpose of this regulation to promote the safe, effective and efficient use of installed solar energy systems that reduce on-site consumption of utility-supplied energy while protecting the health, safety and welfare of adjacent and surrounding land uses and [lots/parcels/properties]. This Ordinance seeks to:

Provide [lot/parcel/property] owners and business owners/operators with flexibility in satisfying their on-site energy needs.

Reduce overall energy demands within the [Municipality/Township/Borough/community] and to promote energy efficiency.

Integrate alternative energy systems seamlessly into the [Municipality/Township/Borough/community]'s neighborhoods and landscapes without diminishing quality of life in the neighborhoods.

Section 3. Applicability.

This Ordinance applies to building-mounted and ground-mounted systems installed and constructed after the effective date of the Ordinance.

Solar PV systems constructed prior to the effective date of this Ordinance are not required to meet the requirements of this Ordinance.

Any upgrade, modification or structural change that materially alters the size or placement of an existing solar PV system shall comply with the provisions of [Section/Article].

Section 4. Permitted Zoning Districts.

Building-mounted and ground-mounted systems are permitted in all zoning districts as an accessory use to any lawfully permitted principal use on the same [lot/parcel/property] upon issuance of the proper permit pursuant to [Section/Article] and upon compliance with all requirements of this section and as elsewhere specified in this Ordinance.

Building-integrated systems, as defined by this Ordinance, are not considered an accessory use and are not subject to the requirements of this Ordinance.

Section 5. Location Within a [Lot/Parcel/Property].

Building-mounted systems are permitted to face any rear, side and front yard or any unregulated yard area as defined in [Section/Article] of this Ordinance. Building-mounted systems may only be mounted on lawfully permitted principal or accessory structures.

Ground-mounted systems are permitted based on the requirements for accessory uses or structures in the property's zoning district.

**PERMITTED LOCATION: BUILDING-MOUNTED SOLAR PV SYSTEM
ISOMETRIC**

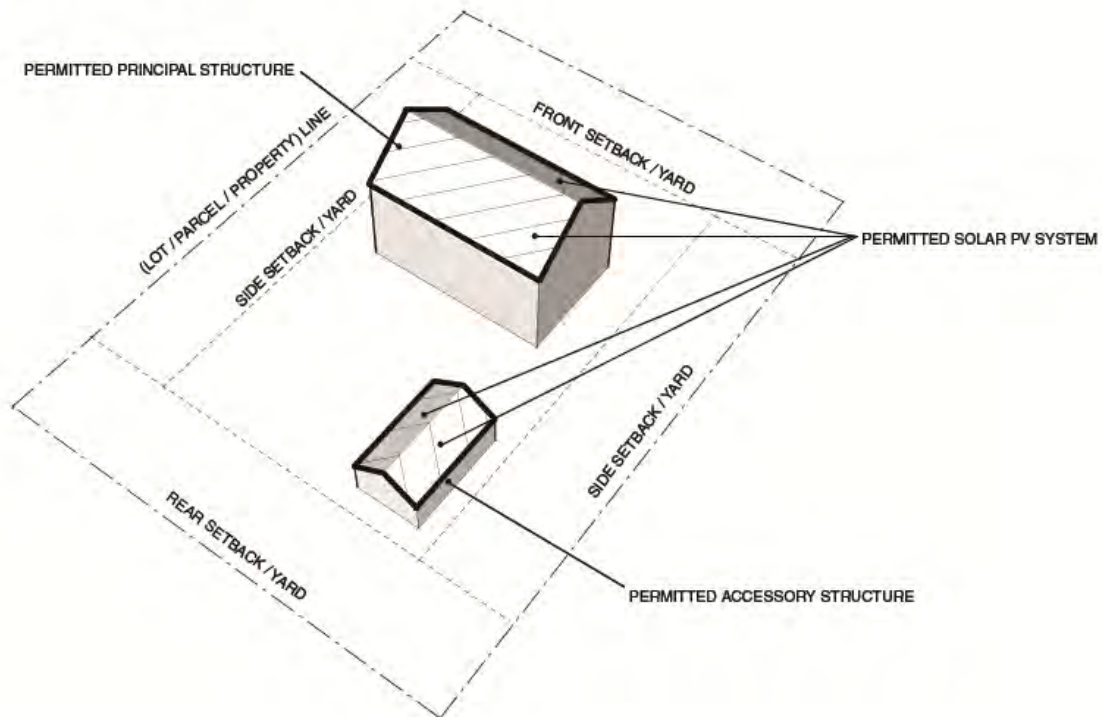

Section 6. Design and Installation Standards.

The solar PV system must be constructed to comply with the Pennsylvania Uniform Construction Code (UCC), Act 45 of 1999, as amended, and any regulations adopted by the Pennsylvania Department of Labor and Industry as they relate to the UCC, except where an applicable industry standard has been approved by the Pennsylvania Department of Labor and Industry under its regulatory authority.

All wiring must comply with the National Electrical Code, most recent edition, as amended and adopted by the Commonwealth of Pennsylvania.

[Optional add-on] *For ground-mounted systems, all exterior electrical lines must be buried below the surface of the ground where possible or be placed in conduit.*

The solar PV system must be constructed to comply with the most recent fire code as amended and adopted by the Commonwealth of Pennsylvania.

Section 7. Setback Requirements.

Ground-mounted systems. Ground-mounted systems are subject to the accessory use or structure setback requirements in the zoning district in which the system is to be constructed.

The required setbacks are measured from the [lot/parcel/property] line to the nearest part of the system. No part of the ground-mounted system shall extend into the required setbacks due to a tracking system or other adjustment of solar PV related equipment or parts.

Optional Add-On: Electrical Lines

Different municipalities have different types of land uses, lot sizes and regulations so they may want different regulations on solar installations. It may be beneficial or desirable to include this optional add-on in a more compact urban municipality while it may restrict the installation of solar by adding significantly to the cost of an installation in a more rural municipality with larger lot sizes (where ground-mounted systems could be located a significant distance from buildings on the lot). Each municipality must decide if an optional add-on is appropriate in their community.

Section 8. Height Restrictions.

Notwithstanding the height limitations of the zoning district:

For a building-mounted system installed on a sloped roof that faces the front yard of a [lot/parcel/property], the system must be installed at the same angle as the roof on which it is installed with a maximum distance, measured perpendicular to the roof, of eighteen (18) inches between the roof and highest edge or surface of the system.

HEIGHT RESTRICTION, SLOPED ROOF FACING FRONT YARD: BUILDING-MOUNTED SOLAR PV SYSTEM ELEVATION

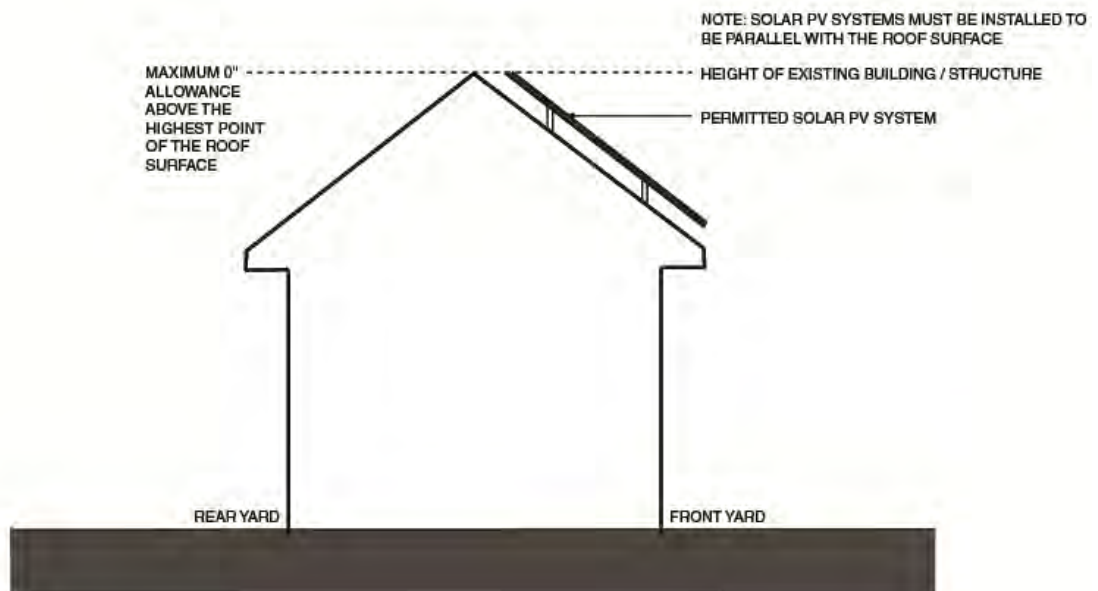

For a building-mounted system installed on a sloped roof, the highest point of the system shall not exceed the highest point of the roof to which it is attached.

HEIGHT RESTRICTION, SLOPED ROOF FACING REAR OR SIDE YARD: BUILDING-MOUNTED SOLAR PV SYSTEM ELEVATION

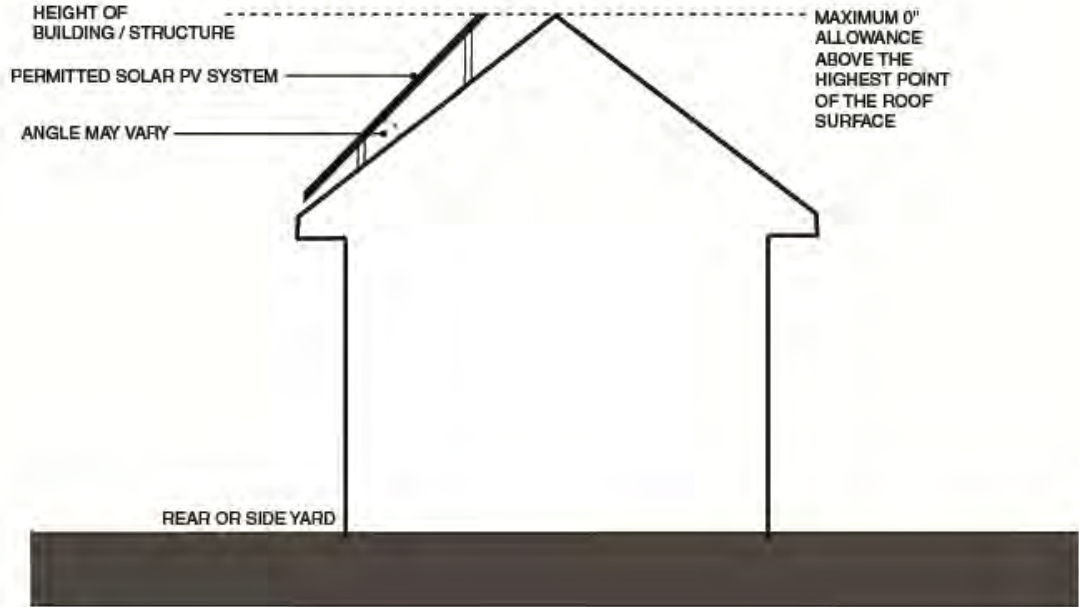

Notwithstanding the height limitations of the zoning district:

For a building-mounted system installed on a flat roof, the highest point of the system shall be permitted to extend up to six (6) feet above the roof to which it is attached.

HEIGHT RESTRICTION, FLAT ROOF: BUILDING-MOUNTED SOLAR PV SYSTEM ISOMETRIC

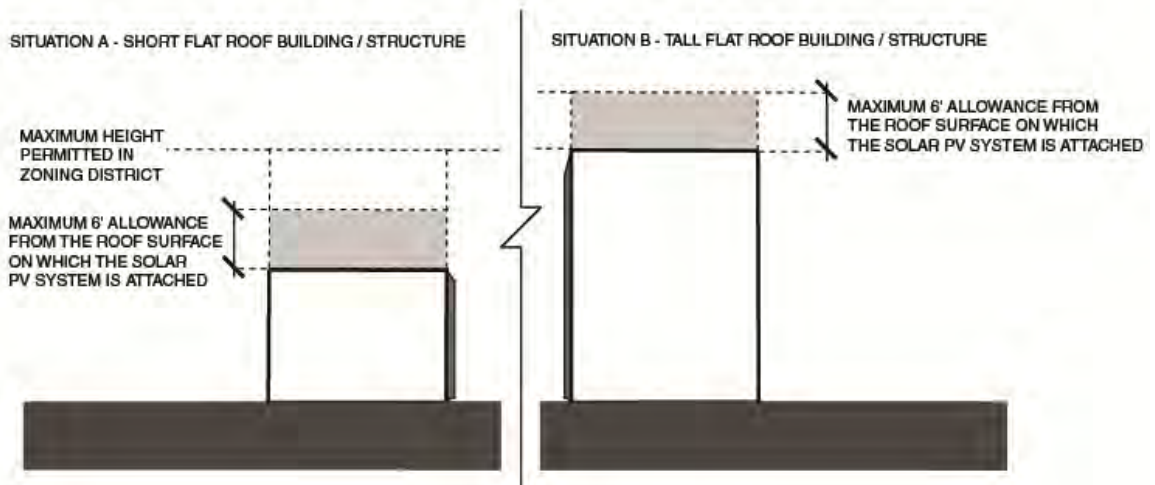

Ground-mounted systems may not exceed the permitted height of accessory structures in the zoning district where the solar PV system is to be installed.

HEIGHT RESTRICTION: GROUND-MOUNTED SOLAR PV SYSTEM ELEVATION

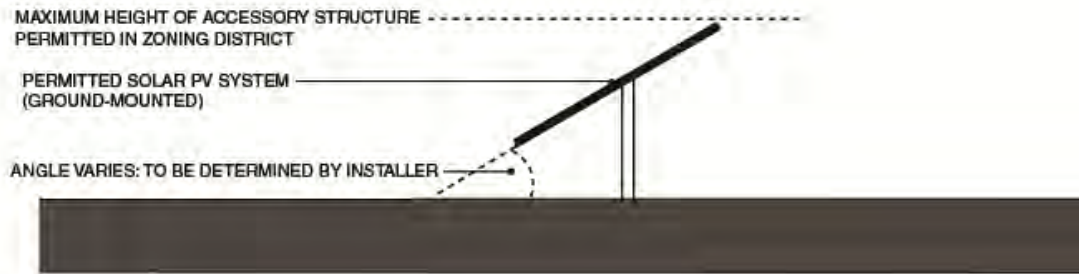

Section 9. Screening and Visibility.

Building-mounted systems on a sloped roof shall not be required to be screened.

[Optional add-on] Building-mounted systems mounted on a flat roof shall not be visible from the public right-of-way within a [# (number) foot] radius of the property, exclusive of an alley as defined by this Ordinance, at a level of 5 (five) feet from the ground in a similar manner as to any other rooftop HVAC or mechanical equipment. This can be accomplished with architectural screening such as a building parapet or by setting the system back from the roof edge in such a manner that the solar PV system is not visible from the public right-of-way within a [# (number) foot] radius when measured at a distance of 5 (five) feet from the ground.

Optional Add-On: Screening and Visibility

It may be beneficial or desirable to include this optional add-on in a more compact urban municipality while it may not be necessary or desirable in a more rural community. Each municipality must decide if an optional add-on is appropriate in their community. However, note that adding screening requirements may reduce the amount of solar that can be used on the rooftop.

SCREENING & VISIBILITY, FLAT ROOF: BUILDING-MOUNTED SOLAR PV SYSTEM PLAN

SITUATION A: CORNER LOT

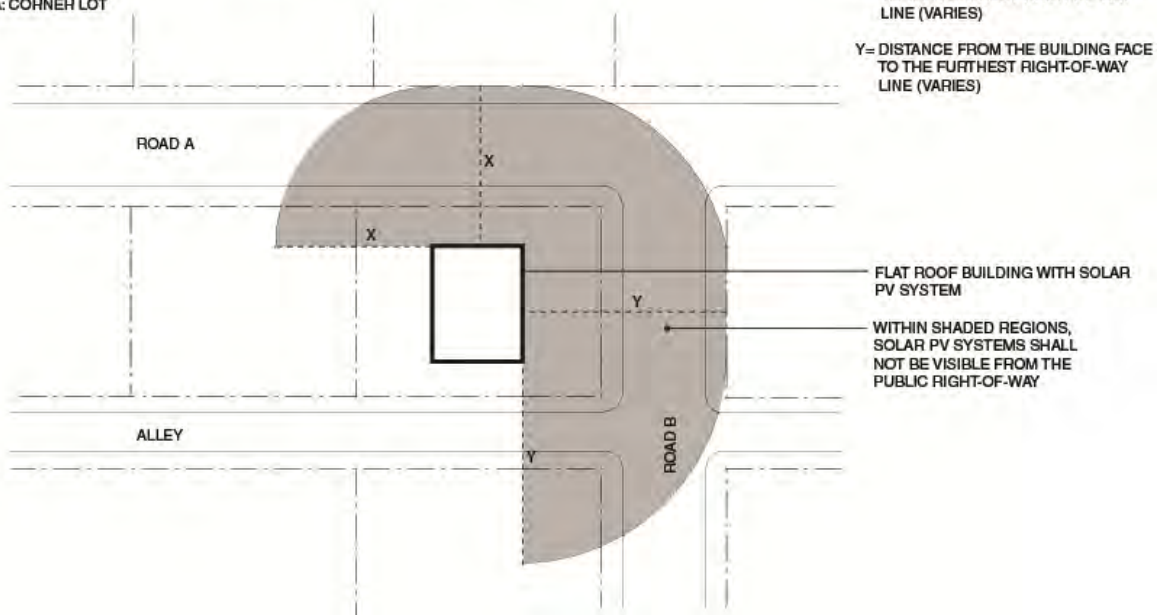

SCREENING & VISIBILITY, FLAT ROOF: BUILDING-MOUNTED SOLAR PV SYSTEM PLAN

SITUATION B: INTERIOR LOT

X = DISTANCE FROM THE BUILDING FACE TO THE FURTHEST RIGHT-OF-WAY LINE (VARIES)

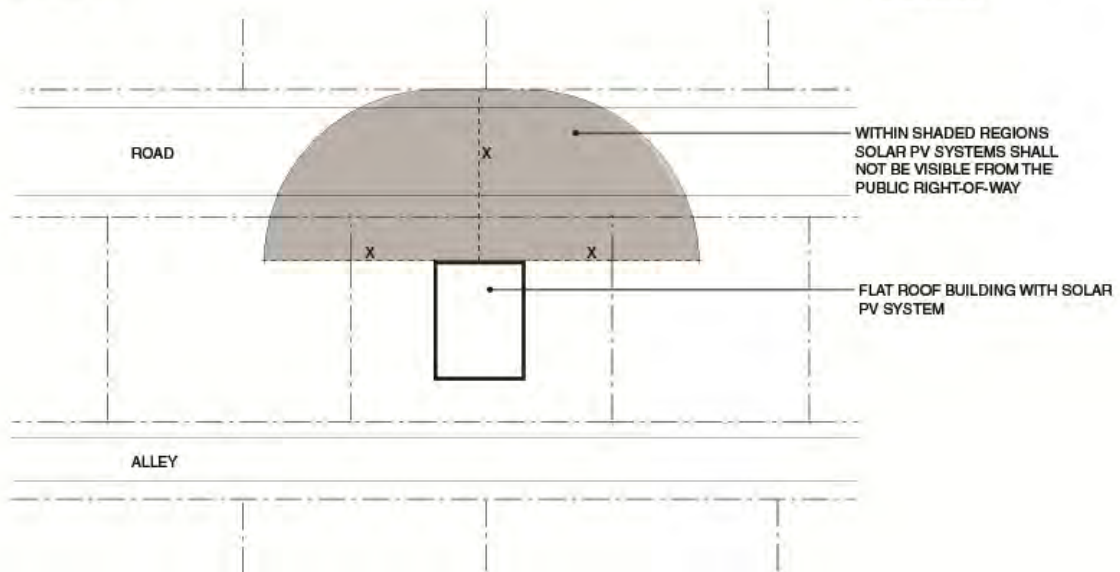

SCREENING & VISIBILITY, FLAT ROOF: BUILDING-MOUNTED SOLAR PV SYSTEM ELEVATION

SITUATION A: WITHOUT BUILDING PARAPET

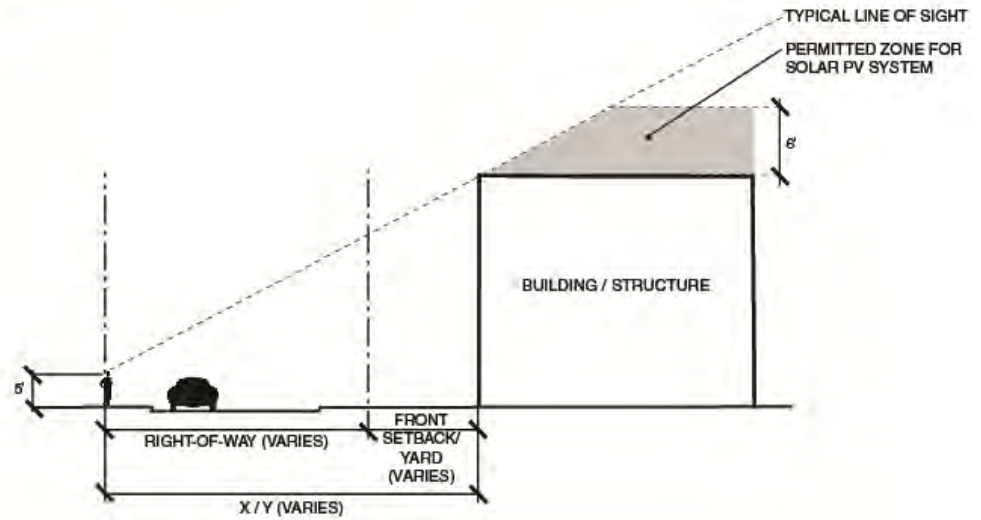

SCREENING & VISIBILITY, FLAT ROOF: BUILDING-MOUNTED SOLAR PV SYSTEM ELEVATION

SITUATION B: WITH BUILDING PARAPET

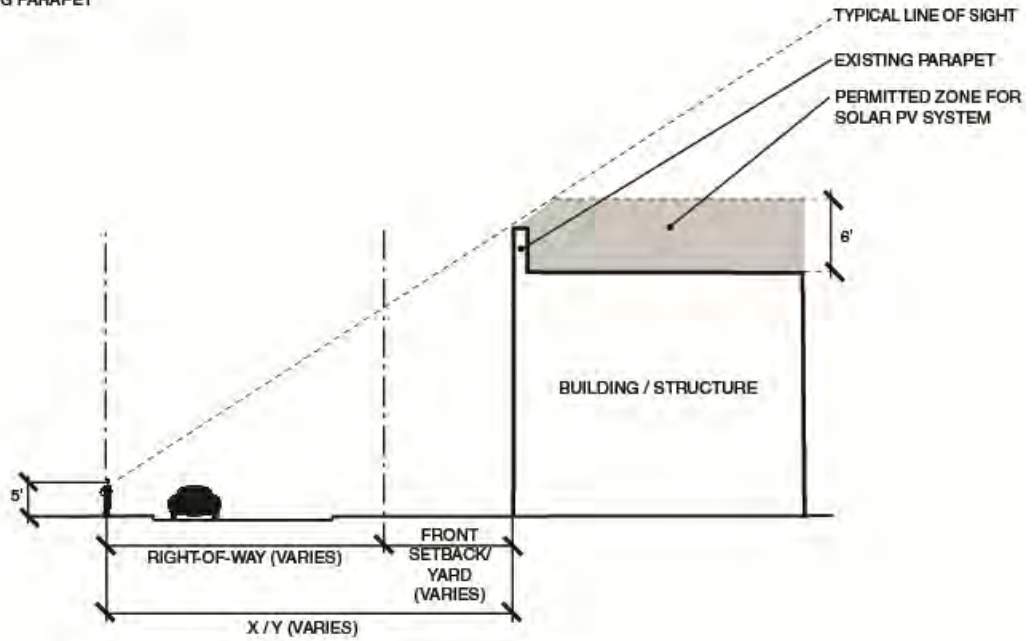

Section 10. Impervious [Lot/Parcel/Property] Coverage Restrictions.

The surface area of any ground-mounted system, regardless of the mounted angle of any portion of the system, is considered impervious surface and shall be calculated as part of the [parcel/property] lot coverage limitations for the zoning district. If the ground-mounted system is mounted above existing impervious surface, it shall not be calculated as part of the [parcel/property] lot coverage limitations for the zoning district.

Section 11. Non-conformance.

Building-mounted systems:

If a building-mounted system is to be installed on any building or structure that is non-conforming because its height violates the height restrictions of the zoning district in which it is located, the building-mounted system shall be permitted so long as the building-mounted system does not extend above the peak or highest point of the roof to which it is mounted and so long as it complies with the other provisions of this Ordinance.

NON-CONFORMING BUILDING, SLOPED ROOF FACING FRONT YARD: BUILDING-MOUNTED SOLAR PV SYSTEM ELEVATION

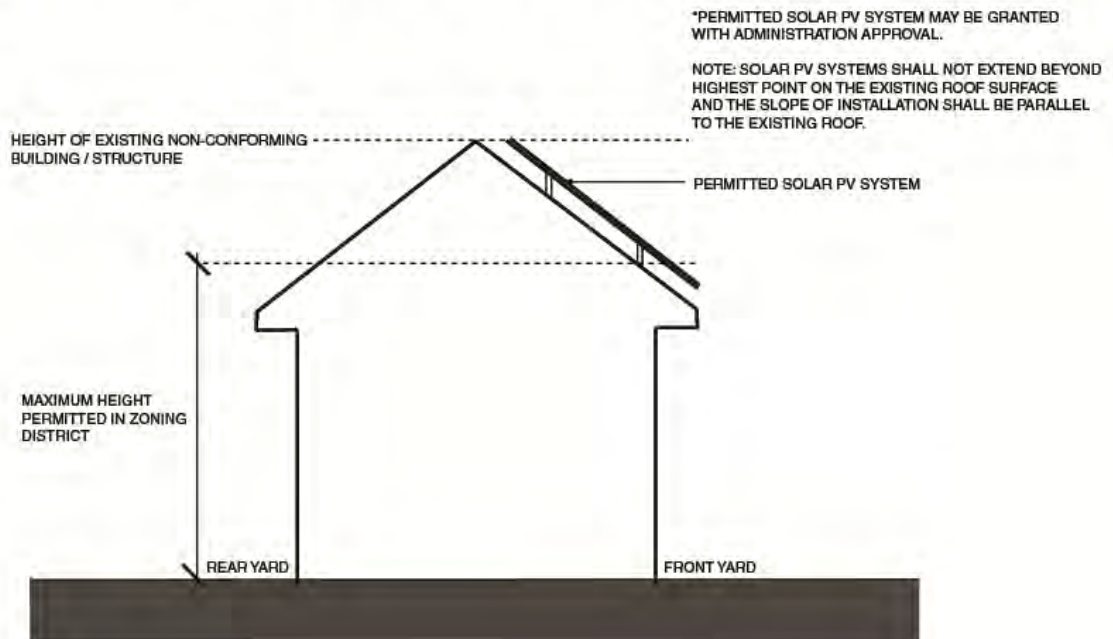

NON-CONFORMING BUILDING, SLOPED ROOF FACING REAR OR SIDE YARD: BUILDING-MOUNTED SOLAR PV SYSTEM ELEVATION

*PERMITTED SOLAR PV SYSTEM MAY BE GRANTED WITH ADMINISTRATION APPROVAL.

NOTE: SOLAR PV SYSTEMS SHALL NOT EXTEND BEYOND HIGHEST POINT ON THE EXISTING ROOF SURFACE

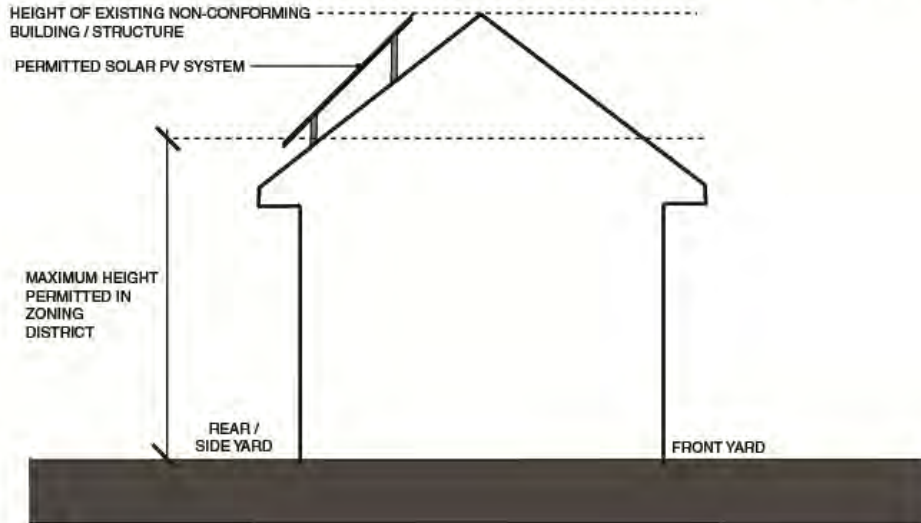

If a building-mounted system is to be installed on a building or structure on a non-conforming [lot/parcel/property] that does not meet the minimum setbacks required and/or exceeds the lot coverage limits for the zoning district in which it is located, a building-mounted system shall be permitted so long as there is no expansion of any setback or lot coverage non-conformity and so long as it complies with the other provisions of this Ordinance.

NON-CONFORMING LOT, SETBACKS, AND / OR LOT COVERAGE LIMITS: BUILDING-MOUNTED SOLAR PV SYSTEM ISOMETRIC

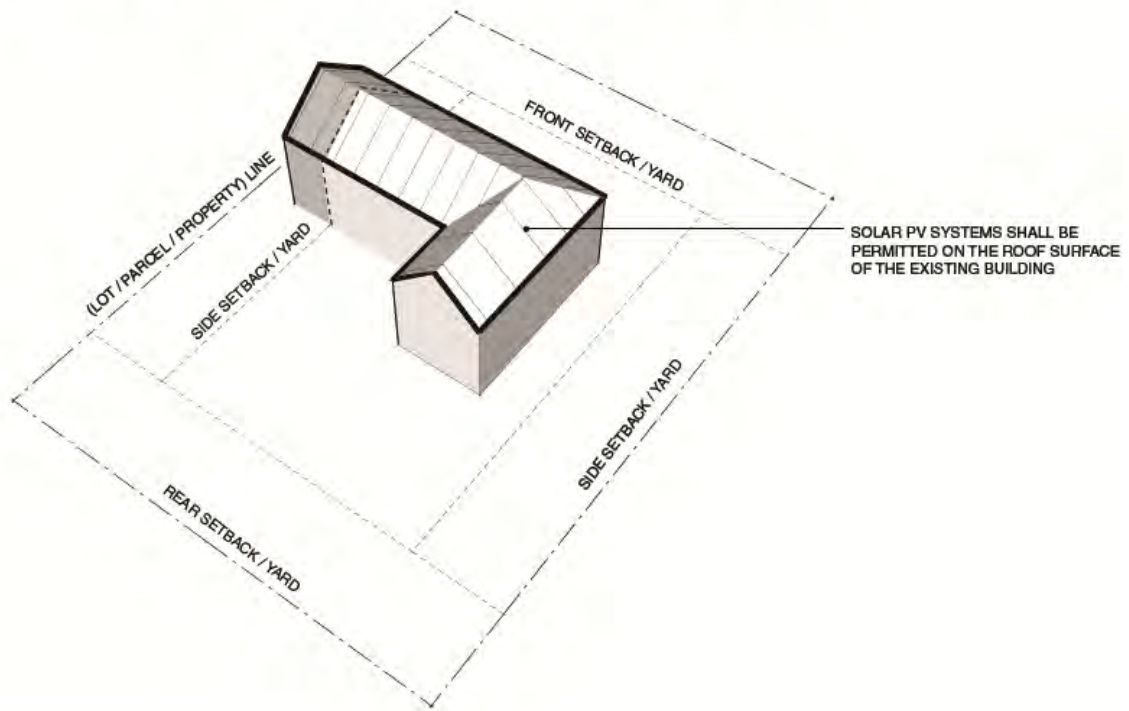

Ground-mounted systems:

If a ground-mounted system is to be installed on a [lot/parcel/property] containing a structure that is non-conforming because the required minimum setbacks are exceeded, the proposed system shall be permitted so long as the system does not encroach into the established setback for the [lot/parcel/property]. If a ground-mounted system is to be installed on a [lot/parcel/property] that is non-conforming because it violates zoning district requirements other than setbacks, then a variance must be obtained for the proposed installation.

**NON-CONFORMING LOT, SETBACKS: GROUND-MOUNTED SOLAR PV SYSTEM
ISOMETRIC**

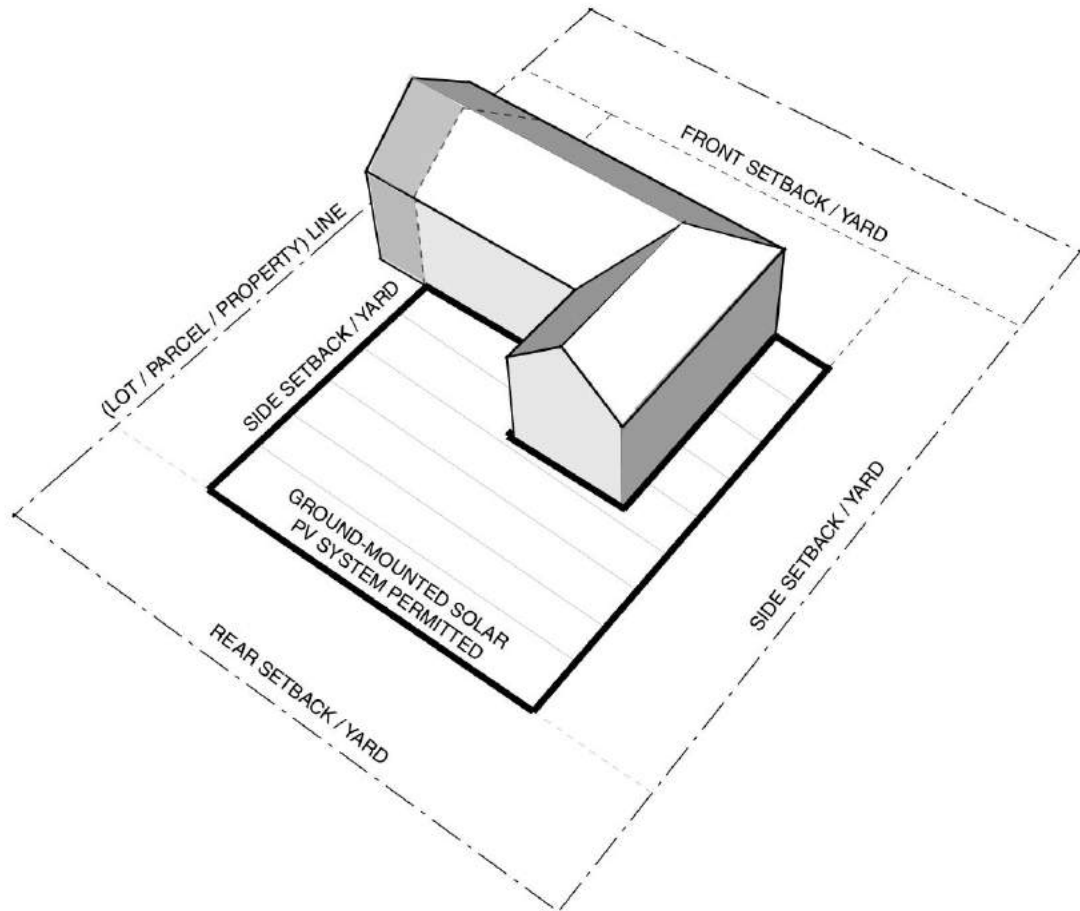

Section 12. Signage and/or Graphic Content.

No signage or graphic content may be displayed on the solar PV system except the manufacturer's badge, safety information and equipment specification information. Said information shall be depicted within an area no more than thirty-six (36) square inches in size.

Section 13. Performance Requirements.

All solar PV systems are subject to compliance with applicable performance standards detailed elsewhere in the Zoning Ordinance

Section 14. Inspection, Safety and Removal.

The [Municipality/Township/Borough] reserves the right to inspect a solar PV system for building or fire code compliance and safety.

If upon inspection the [Municipality/Township/Borough] determines that a fire code or building code violation exists, or that the system otherwise poses a safety hazard to persons or property, the [Municipality/Township/Borough] may order the [owner/property owner/land owner/facility owner/operator] to repair or remove the system within a reasonable time. Such an order shall be in writing, shall offer the option to repair, shall specify the code violation or safety hazard found and shall notify the [owner/property owner/land owner/facility owner/operator] of his or her right to appeal such determination.

If a [owner/property owner/land owner/facility owner/operator] fails to repair or remove a solar PV system as ordered, and any appeal rights have been exhausted, the [Municipality/Township/Borough] may enter the [lot/parcel/property], remove the system and charge the [owner/property owner/land owner/facility owner/operator] for all costs and expenses of removal, including reasonable attorney's fees or pursue other legal action to have the system removed at the [owner/property owner/land owner/facility owner/operator]'s expense.

In addition to any other available remedies, any unpaid costs resulting from the [Municipality/Township/Borough]'s removal of a vacated abandoned or de-commissioned solar PV system shall constitute a lien upon the [lot/parcel/property] against which the costs were charged. Legal counsel of the [Municipality/Township/Borough] shall institute appropriate action for the recovery of such cost, plus attorney's fees, including, but not limited to filing of municipal claims pursuant to 53 P.S. § 7107, et seq., for the cost of such work, 6% interest per annum, plus a penalty of 5% of the amount due plus attorney's fees and costs incurred by the [Municipality/Township/Borough] in connection with the removal work and the filing of the [Municipality/Township/Borough]'s claim.

Section 15. Permit Requirements.

Before any construction or installation on any solar PV system shall commence, a permit issued by [Municipality name] shall be obtained to document compliance with this Ordinance.

SECTION C: PERMITTING

PERMITTING OVERVIEW
SOLAR PERMIT APPLICATION
SUGGESTED PERMIT FEES



PERMITTING OVERVIEW

Model Permit

The model Solar Photovoltaic (PV) Permit was framed largely after the Solar American Board of Standards and Codes (Solar ABCs) expedited solar permitting process and the Philadelphia Streamlined Standards for Solar PV Permit process

<https://business.phila.gov/Pages/SolarPVSystemInstallations.aspx>.

Elements from the following sources were also incorporated:

- San José Solar Permitting Requirements
<http://www.sanjoseca.gov/building/PDFHandouts/1-10Solar.pdf>,
- Arizona Solar Energy Task Force recommendations
<http://www.azenergy.gov/doclib/2011%20GSETF%20Recommendations.pdf>,
- the California Sample Submittal Requirements for Solar Permit
http://www.opr.ca.gov/docs/Sample_Submittal_Requirements_for_Permit_Application.pdf,
- the Oregon State Solar Checklist
http://www.cbs.state.or.us/bcd/programs/solar/state_solar_checklist_100710.pdf and
- the Sacramento Solar PV Permit Packet
http://www.cityofsacramento.org/dsd/documents/Solar_PV_Permit_Packet_81611.pdf

As with the Philadelphia and San José (California) approaches, the following model Solar PV Permit process folds the building and electrical permit into one application for small PV systems. Applying for a solar permit within the City of San José is simple. The processing time for most single-family solar permits can conveniently be handled over the counter by the solar installer after filling out a simplified one-page application. San José is a national leader in the promotion and use of solar technologies in the commercial, residential and municipal sectors with more than 2,000 solar systems, totaling more than 27

megawatts at the end of 2010. Through best practices in permitting and inspections, San José has made installing solar easy for all sectors, which has contributed to the impressive rate of adoption of solar systems in the City.

The model Solar PV Permit was designed so that a majority of small PV systems can be permitted quickly and easily. It is not intended to apply to all types of PV systems. The primary need and value for this process is for systems of less than 10-15 kW maximum power output. As PV systems increase in size and complexity, the ability

to handle these projects via a standard framework diminishes. This is not to say that larger systems cannot be handled in a straightforward manner. Many larger PV system projects may be approved with minimum review as is required with smaller systems. A key difference between small and large projects is the inability of small projects to absorb engineering review costs.

This Solar PV Permit process is intended to simplify the structural and electrical review of a small PV system project and minimize the need for detailed engineering studies and unnecessary delays. It is not the intent of this PV permit process to circumvent the engineering process. Rather, the intent is to address the engineering concerns by recognizing the similarities among these smaller systems and establishing guidelines to determine when a PV project is within the boundaries of typical, well-engineered systems. To this end, a three-page permit form was devised to outline the process and define what qualifies for this streamlined permitting. Explanation and instructions to the rationale and details are provided so that contractors and local jurisdictions using the form have a description of how to provide the required information. The roof-mounted PV systems that most homeowners install have a low enough weight/area ratio that they cannot overload standard roofs. They are designed so that most roofs will hold them. Many places such as Philadelphia, PA; San Jose, CA, and the state of Vermont forego building permits for roof-mounted rooftop installations that do not exceed standard load bearing and wind shear limits in order to avoid unnecessary

reviews. The model Solar PV permitting process confirms that the systems do not exceed these limits.

In Philadelphia, the electrical inspectors (including 3rd party inspectors) have agreed to review the basic structural elements when they are reviewing the electrical work. This review was also built into the model Solar PV Permit however, the San José process does not require this review. In addition, the model Solar PV Permit requires the solar installation company to assume all liability for the installation, including the ability of the roof to support the system. Larger solar PV systems may require more extensive reviews, such as consultation with a design professional when the system exceeds is more than 5 lbs. per sq. ft.

The following is the annotated model permitting application containing supporting explanations regarding the various items on the application. Please also refer to the legal notes regarding permitting in Section A. The blank permitting application can be found in the Appendix. An interactive permitting application is available so that an applicant can fill out the forms electronically. This also allows municipalities to offer the application via their website and accept applications online or by email.

The model Solar PV Permit has been reviewed by attorneys at Cozen O'Conner to ensure compliance with Pennsylvania Uniform Construction Code and other applicable regulations.



Solar Photovoltaic (PV) Permit Application

Annotated Version

Applicability: This Solar Photovoltaic Permit Application may be used for systems with the following qualifications:

- **A total inverter capacity with a continuous AC power output of 13,440 watts (13.44kW) or less;**
Explanation: The limit is set to stay generally within electrical interconnections that would be considered simple and possibly able to meet the 120% of busbar rating allowance in NEC 690.64(B) in a residence (Minimum breaker for a 13.44 kWac PV system is 70 amps at 240Vac). A 70-amp breaker is important since a 225-amp busbar in a 200-amp panel will allow a 70-amp PV breaker. Since this does happen from time to time, and an installer can choose to install such a panelboard, it is considered the largest “simple” PV system for purposes of this model and also of the Solar ABCs.
- **A distributed weight load of less than or equal to five (5) lbs. per sq. ft.;**
Explanation: The 5 lbs/ft² allowance is used to identify the maximum allowable additional weight for roofs that are exchanging the allowable live load for a dead load that prevents live load such as people walking on the roof. The combined weight of a roof with one layer of roofing material and the PV systems (that are 5lbs per sq. ft. or less) is well under snow load requirements for Pennsylvania. PV modules typically weigh less per sq. ft. than an additional layer of shingles for which most jurisdictions in Pennsylvania do not require a permit.
- **A point load of less than or equal to 45 lbs. per sq. ft.;**
Explanation: 45 lbs has been used by some jurisdictions as a reasonable level below which point loading of roof joists and trusses can be ignored. Most standard mounting systems have point loadings of 25-35 lbs. per attachment.
- **Installed on a roof with a single layer of lightweight roofing material;**
Explanation: A single layer of roofing is figured into the calculation so that the normal weight allowance for additional roof layers is unused and available for the weight of the PV system.

- A mounting structure with an engineered product designed to mount PV modules with no more than an 18" gap beneath the module frames;**
Explanation: Non-engineered racking systems have undefined capabilities. PV systems should only be mounted using systems that are engineered and designed for that purpose. Structural loading of a roof is more complex when modules are angled more than 18" above the roof surface. For simplicity, this process has been limited to PV arrays that are mounted parallel to the roof surface or angled with no more than an 18" gap between the module frame and the roof surface. If an installer chooses to mount the PV modules with a larger gap or if they use a mounting system of unique design, then the mounting design would require a review by a design professional. Depending on the wind loading requirements of a particular jurisdiction, the spacing or attachments may be dictated by the manufacturer's directions. For instance, a particular manufacturer may allow a 72" attachment spacing for a 90 mph windspeed design, but the spacing reduces to a maximum of 48" when the design windspeed exceeds 100 mph.
- The installation is overseen by a trained solar professional and a licensed Pennsylvania contractor;**
Explanation: Since solar PV installation requires a broad range of technical, safety, electrical and structural knowledge, it is important that trained professionals are installing solar equipment.
- The installer assumes liability for the installation and the roof structure as it pertains to the installation.**

If the System does not meet any of the above qualifications or the answer is "NO" to any of the questions in Steps 1 and 2 below, the municipality may require further information or review as it deems appropriate.

Explanation: if a solar system weighs more than 5 lbs per sq. ft., for example, such as the case with many ballasted installations, further review by a design professional may be necessary.

Questions regarding this Application should be directed to: *[Insert Name, phone, email]*.
 Definitions of terms used in this Application and sample application documents can be found in the *Solar Guide for Municipalities*.

Materials needed upon permit application submission

- 1. A completed copy of this Solar Photovoltaic Permit Application.**
- 2. A site plan showing location of major components on the property. This drawing need not be to scale, but it should represent relative location of components at site (A sample site plan follows)**

Explanation: This is a simple diagram to show where the equipment is located on the property. This can be a zone-clearance plot plan with the equipment clearly shown and identified on the plan. If PV array is ground-mounted, clearly show that system will be mounted within allowable zoned setbacks.

- 3. A single-line electrical diagram showing the configuration of the photovoltaic (“PV”) array, the wiring system, the overcurrent protection, the inverter, the disconnects, any required signs, and the AC connection to the building.**

Explanation: The cornerstone of a simplified permit process is the ability to express the electrical design with a generic electrical diagram. The attached diagrams have been designed to accurately represent the majority of single-phase, residential-sized PV systems. PV systems may vary dramatically in PV array layout and inverter selection. However, the majority of small-scale, residential-sized PV systems can be accurately represented by one of the four diagrams for standard string, micro-inverter, AC module or supply side connection systems.

- 4. Specification sheets and installation manuals (if available) for all manufactured components including, but not limited to PV modules, inverter(s), combiner box, disconnects, and mounting system.**

Explanation: At a minimum, specification sheets must be provided for all major components. In addition to the components listed, other important components may be specialty fuses, circuit breakers, or any other unique product that may need to be reviewed by the local jurisdiction. Installation manuals are also listed in this item. This is referring to the brief versions of manuals that are reviewed by the listing agency certifying the product. Some detailed installation manuals can be several dozens or hundreds of pages. If the local jurisdiction feels it is necessary to review these large documents, a good alternative would be for the documents to be supplied electronically, rather than in print.

5. An application fee of \$_____. [to be filled in by municipality]

Basic Information

Brief System Description _____

(eg, number and power rating of panels; total combined power rating of system; panel and inverter manufacturer; inverter/microinverter output, location of system on property)

Address of Project: _____

Applicant Name: _____

Address: _____

Telephone Number: _____

E-mail address: _____

Property Owner (if different from the Applicant):

Name: _____

Address: _____

Telephone Number: _____

E-mail address: _____

Owner of Solar System (if different from Applicant or Property Owner):

Name: _____

Address: _____

Telephone Number: _____

E-mail address: _____

Installation Company (The System must be installed by a contractor licensed by the Commonwealth of Pennsylvania):

Name: _____

Address: _____

Telephone Number: _____

E-mail address: _____

HIC#: _____

Installer Qualification: The installation of the System will be overseen by (check one below):

- NABCEP certified solar equipment installer
- UL certified solar equipment installer
- Electrical contractor with a license accepted by the municipality
- Solar installer on the approved list for the Pennsylvania Sunshine grant program

Name of person with above qualification:



Step 1: Structural Review of PV Array Mounting System

A. Roof Information:

YES NO Does the roof have a single roof covering?

YES NO Is the roofing type lightweight (composition, lightweight masonry, metal, etc.)?

Roofing Material Description _____

Explanation: Roof structures supporting heavier roofing materials (e.g. slate, heavy masonry, tile) may not have the assumed dead loading and live loading capacities that are found with lighter weight roofing materials and may justify a further review to clarify whether the roof structure is either in compliance or needs enhancement.

YES NO Weatherproofing sealant is compatible with the roofing material. Describe method *and* type of weatherproofing roof penetrations (e.g. flashing, caulk) _____

YES NO The roof was visually inspected for pre-existing damage. (If damage is noted, provide details for any work necessary to repair the existing roof structure.)

B. Mounting System Information:

YES NO Is the mounting structure an engineered product designed to mount PV modules with no more than an 18" gap beneath the module frames?

If YES, complete information on the mounting system below:

- a. Mounting System Manufacturer _____
Product Name and Model# _____
- b. Total Weight of PV Modules and Rails _____ lbs
- c. Total Number of Attachment Points _____
- d. Weight per Attachment Point (Total Weight of Modules and Rails (from line b.) ÷ Total Number of Attachment Points (from line c.) = _____ lbs.

YES NO Is the point load weight in line (d.) above, less than or equal to 45 lbs? If YES, complete the following:

- e. Maximum Spacing Between Attachments Points on a Rail = _____ inches
(see product manual for maximum spacing allowed based on maximum design wind speed)
- f. Total Surface Area of PV Modules (square feet) _____ ft².
- g. Distributed Weight of PV Module on Roof (Total Weight of PV Modules and Rails (from line b.) ÷ Total Surface Area of PV Modules (from line f.) = _____ lbs/ft².

YES NO Is the distributed weight in line (g) above, less than or equal to 5 lbs/ft²?

Step 2: Review of PV System (Calculations for Electrical Diagram)

YES NO 1. The total inverter capacity has a continuous AC power output of 13,440 Watts or less?

YES NO 2. PV modules, utility-interactive inverters, and combiner boxes are identified for use in PV systems.

Explanation: PV utility-interactive inverters must be specifically listed and labeled for this application [NEC 690.60 and 690.4] (Brackets refer to sections in the 2011 NEC throughout this document.) Without this specific identification process an unacceptable amount of review would be necessary to approve an inverter. Inverters that pass UL1741 and are listed as “utility-interactive” have met the requirement. Over 500 inverters currently meet this requirement. An inclusive list of these inverters is available online at <http://gosolarcalifornia.com/equipment/inverter.php>. PV modules must also be listed and identified for use in PV systems [NEC 690.4]. PV modules that pass UL1703 and have a 600-Volt maximum voltage meet the requirement. A list of these modules is available online at <http://gosolarcalifornia.com/equipment/pvmodule.php>. Source circuit combiners must be listed and labeled to meet the dc voltage requirements of the PV system or be specifically tested for PV systems and clearly state the allowable maximum current and voltage [NEC 690.4].

YES NO 3. The PV array is composed of 4 series strings or less per inverter.

Explanation: The purpose of this requirement is to limit the number of options of what can comply as a “simple” system so that a single electrical diagram can be used to describe a large percentage of the systems being installed. The electrical diagram can handle up to 4 strings or branch circuits in parallel. This ensures that the conduit will have no more than eight current carrying conductors, which the ampacity tables in the Solar ABCs have been based upon.

YES NO 4. The AC interconnection point is on the load side of service disconnecting means.

Explanation: Load side interconnections are by far the most common, particularly in residential applications. Any line side connection is covered by NEC 690.64(A) and 230.82. Although line side connections can be quite straightforward, they should require an additional step in the approval process and require a slightly different electrical drawing.

YES NO 5. Can one of the four standard electrical diagrams (standard string system, micro-inverter, AC Module or Supply-Side Connection systems) be used to accurately represent the PV system? (refer to Guide)

Explanation: Each diagram has a corresponding notes form. Interactive PDF diagrams may be available from your Municipality. These diagrams allow values to be input and the page to be saved and printed.

Explanation: The basis for a simplified permit is the use of the standard electrical diagram. Clearly, PV systems can vary significantly in PV array layout and inverter selection. However, the majority of small-scale, residential-sized PV systems can be accurately represented by this diagram. This diagram must be completely filled out in order for the permit package to be considered complete. This diagram is not intended for use with battery-based systems.

Step 3: Inspection of PV System

1. A Pennsylvania certified electrical inspector (the “Inspector”) must conduct an on-site inspection of the System.

2. The Inspector must verify the accuracy of the information provided in Steps 1 and 2 above.

Explanation: This process of the electrical inspector verifying the simple structural information contained in this checklist is replicated from the Philadelphia permitting process, where electrical inspectors, including third party inspectors, have agreed to such arrangements. The process was intended to streamline and expedite the review of most straightforward small PV systems.

3. The Inspector must execute the below verification of the inspection of the System and submit approval to municipality.

Explanation: Municipalities that participated in the SunShot Rooftop Challenge requested verification that the inspector reviewed the simple structural elements in this checklist as well as the electrical information and installation. However, legal responsibility of the PV system installation and the associated roof structure are still assumed by the solar installer.

Certification of the Designated Representative of the Solar Installation Company

I, _____, on behalf of _____ (the "Company") hereby represent and warrant that:

- (a) The information provided in this permit application is accurate and complete to the best of my knowledge;
- (b) The building and its roof are structurally capable of supporting the System; and
- (c) The System will be designed and installed in compliance with the applicable requirements of the Pennsylvania Uniform Construction Code, National Electric Code and other applicable regulatory codes.

The Company hereby assumes all liability associated with the installation of this System, including any liability arising out of or resulting from the roof supporting the System, and shall indemnify, defend and hold harmless [INSERT MUNICIPALITY NAME] and its employees and third party inspectors from and against any claims referring or relating to (1) the accuracy of any information, representation or statement made in this Application; or (2) the representations and warranties made in this Certification.

I have been duly designated by the Company to execute this certification on its behalf.

Installation Company: _____

Installer/Company Representative Name: _____

Signature: _____

Date: _____

For Electrical Inspector: I have inspected this system installation and have verified to the best of my ability that the information provided is accurate.

Inspector Name: _____

Inspector Company: _____

Address: _____

Signature: _____ Date: _____



SUGGESTED PERMIT FEES

Inefficient permitting processes and fees can add significant cost to solar installations, sometimes increasing the price of a routine installation more than \$2,000 ([The Impact of Local Permitting on Cost of Solar Power](#), Sun Run, 2011). However, appropriate procedures and permitting fees that represent the true cost to the municipality for review and inspection can avert unnecessary and burdensome costs for everyone involved. A streamlined and standardized permitting process will also ease the burden on municipalities for review of the systems and will ensure that solar systems are installed safely.

The recommendations in this section are based on research completed by VoteSolar regarding permitting process and fee structure for solar permitting (http://votesolar.org/wp-content/uploads/2012/07/PA_Project-Permit-Report_Final_July2012.pdf) and from the Sierra Club's *Northern California Study of Solar Permitting* (<http://www.solarpermitfees.org/NorCalPVFeeReport.pdf>).

To provide an efficient and cost-appropriate solar permit process, municipalities may choose to follow these recommendations:

1. Require a Fully Completed Solar Application – Requiring the installer to submit a fully completed application before conducting any review will minimize municipal review time. The official accepting the application should verify that all the necessary information is included in the application. This over-the-counter pre-review helps to create an efficient and timely review.
2. Use Fair Flat Fees: Using a flat-fee method instead of a value-based method to assess permit fees streamlines the process and ensures that larger solar energy systems are not arbitrarily penalized. Fees should reflect the time needed for staff to review and issue a permit, which remains fairly constant regardless of system size.

A reasonable permit fee is a total of \$250 or less for small systems (under 15kW), which includes zoning, permitting and electrical inspections. This recommendation is derived from a study of permitting fees across the country and in Pennsylvania by VoteSolar (VoteSolar's study "Solar Permitting in Pennsylvania Municipalities").

A permit fee should reflect the amount of time required by municipal officials to review and inspect an installation. If a flat fee to cover the total review time (zoning/plan review, permit processing and inspection) is not feasible (eg, the municipality uses a third party inspector), then the fees should be broken apart to reflect the individual reviews. A municipality should expect a longer review time for the first few submission with a decrease in review time as experience with the forms is gained. In general, expected timeframes and estimated municipal cost for application processing are approximately:*

- 45 minutes for the zoning and plan check [*estimated municipal cost* - \$35-\$65]
- 45 minutes for miscellaneous permit processing tasks (permit issuance, communication with the applicant, filing, etc) [*estimated municipal cost* - \$35-65]
- One hour for the electrical inspection [*estimated municipal cost* - \$75-\$100]

*The estimated municipal costs are based on billable hourly rates in municipalities participating in the SunShot effort in western Pennsylvania. The estimated times for review are based on the Sierra Club's Northern California Study of Solar Permitting <http://www.solarpermitfees.org/NorCalPVFeeReport.pdf>);

Larger commercial systems may require a longer review and inspection time (particularly for engineering review time). For these systems and for exceptional cases that do not conform to the norm, the municipality might consider charging by the hour (using a billable hourly rate for the job function) for the staff time required *beyond* the anticipated time in the streamlined process outlined above for both plan reviews and inspections.

3. Provide application forms, requirements, and permit fee schedules on the municipality's website to facilitate the application process for solar contractors.
4. Allow Electronic or Over-The-Counter Issuance: Issuing electronic or over-the-counter permits for standard PV systems with complete, error-free applications expedites the permit process. An inspector must still inspect the PV system and approve the permit before it is considered final. Electronic submittal, review and permit issuance is preferred, but over-the-counter submittal, review and permit issuance is a helpful alternative.
5. Standardize Permit Requirements: Municipalities should set and adhere to standard permitting requirements to make the process clear and transparent for the applicant. Using the model solar permitting application for Pennsylvania will provide the necessary information for small scale PV systems and will expedite the permitting process since municipal officials and solar industry will know what to expect with each submission.

6. Schedule Inspections within Reasonable Timeframes: Provide specific times or appointments for inspections or at least give short time windows for inspections (eg, within a two hour span). Schedule inspections soon after the installations are completed (recommended within one business day).

SECTION D: APPENDIX

GENERAL INFORMATION

- Glossary of Terms
- Helpful Contacts, References and Links

PERMIT

- Solar PV System Components
- Sample Diagrams
- Sample Permit
- Sample Cut Sheets

ADDITIONAL RESOURCES

- Solar Access
- Solar and Historic Properties



Glossary of Terms

Array: Any number of electrically connected photovoltaic (PV) modules providing a single electrical output.

Building-Integrated System: A solar photovoltaic system that is constructed as an integral part of a principal or accessory building or structure and where the building-integrated system features maintain a uniform profile or surface of vertical walls, window openings, and roofing. Such a system is used in lieu of a separate mechanical device, replacing or substituting for an architectural or structural component of the building or structure that appends or interrupts the uniform surfaces of walls, window openings and roofing. A building-integrated system may occur within vertical facades, replacing view glass, spandrel glass or other facade material; into semitransparent skylight systems; into roofing systems, replacing traditional roofing materials; or other building or structure envelope systems.

Building-Mounted System: A solar photovoltaic system attached to any part or type of roof on a building or structure that has an occupancy permit on file with the Municipality and that is either the principal structure or an accessory structure on a recorded [*lot/parcel/property*]. This system also includes any solar-based architectural elements.

Cell: The smallest basic solar electric device which generates electricity when exposed to light.

Drip line: The outermost edge of a roof including eaves, overhangs and gutters.

Ground-Mounted System: A solar photovoltaic system mounted on a structure, pole or series of poles constructed specifically to support the photovoltaic system and not attached to any other structure.

HVAC: Equipment used to heat, cool or ventilate a structure.

Impervious Surface: A surface area that prevents or retards the infiltration of water into the soil and/or a hard surface area that causes water to run off the surface of the ground in greater quantities or at an increased rate of flow from the conditions prior to development, construction, building or installation.

Interconnection: The technical and practical link between the solar generator and the grid providing electricity to the greater community.

Kilowatt (kW): A unit of electrical power equal to 1,000 Watts, which constitutes the basic unit of electrical demand. A watt is a metric measurement of power (not energy) and is the rate (not the duration) at which electricity is used. 1,000 kW is equal to 1 megawatt (MW).

Module: A module is the smallest protected assembly of interconnected PV cells.

MPC: The Municipalities Planning Code or MPC (Pennsylvania Act of 1968, P.L.805, No. 247) empowers counties and municipalities, individually or jointly, to plan their development and to govern the same by zoning, subdivision and land development ordinances and additional tools.

Net Metering Agreement: An agreement with a local electric utility that allows customers to receive a credit for surplus electricity generated by certain renewable energy systems.

Photovoltaic (PV): A semiconductor based device that converts light directly into electricity.

Solar-based Architectural Element: Structural/architectural element that provides protection from weather that includes awnings, canopies, porches or sunshades and that is constructed with the primary covering consisting of solar PV modules, and may or may not include additional solar PV related equipment.

Solar Photovoltaic (PV) Related Equipment: Items including a solar photovoltaic cell, panel or array, lines, mounting brackets, framing and foundations used for or intended to be used for collection of solar energy.

Solar Photovoltaic (PV) System: A solar collection system consisting of one or more building- and/or ground-mounted systems, solar photovoltaic cells, panels or arrays and solar related equipment that rely upon solar radiation as an energy source for collection, inversion, storage and distribution of solar energy for electricity generation. A solar PV system is a generation system with a nameplate capacity of not greater than 50 kilowatts if installed at a residential service or not larger than 3,000 kilowatts at other customer service locations and do not produce excess on-site energy greater than currently permitted by Pennsylvania Public Utility Commission guidelines.

Tracking System: A number of photovoltaic modules mounted such that they track the movement of the sun across the sky to maximize energy production, either with a single-axis or dual-axis mechanism.

Unregulated Yard Area: Area not within a building and not in a defined setback or yard area.

Helpful Contacts, References and Links

PennFuture

425 6th Ave., Ste. 2770

Pittsburgh, PA 15219

412-258-6680

<http://www.pennfuture.org>

Southwestern Pennsylvania Commission

Two Chatham Center Suite 500

112 Washington Place

Pittsburgh, PA 15219

(412) 391-5590 (P)

comments@spcregion.org

<http://www.spcregion.org>

CONNECT

Congress of Neighboring Communities

Graduate School of Public and International Affairs

University of Pittsburgh

3621 Wesley W. Posvar Hall

230 South Bouquet Street

Pittsburgh, PA 15260

<http://www.connect.pitt.edu>

Allegheny County

436 Grant Street Room 202

Pittsburgh, PA 15219-2495

Phone: (412) 350-6109

<http://www.alleghenycounty.us/>

City of Pittsburgh

City-County Building

414 Grant Street

Pittsburgh, PA 15219

(412) 255-2626

<http://www.city.pittsburgh.pa.us/>

Information for Municipalities

Photovoltaic Online Training for Code Officials - National Training & Education Resource (NTER) website (<https://www.nerlearning.org/>), enter 'Photovoltaics' in the search bar.

Solar Powering Your Community: A Guide for Local Communities -

http://www4.eere.energy.gov/solar/sunshot/resource_center/sites/default/files/solar-powering-your-community-guide-for-local-governments.pdf

Solar Industry Training and Certification Programs:

NABCEP – North American Board of Certified Energy Providers - <http://www.nabcep.org/>

Underwriters Laboratory (UL) Solar Certification -

<http://www.ul.com/global/eng/pages/offerings/industries/energy/renewable/photovoltaics/>

Approved Solar Installer List under the Pennsylvania SunShine Grant Program -

http://www.portal.state.pa.us/portal/server.pt/community/grants_loans_tax_credits/10395/PA_Sunshine_Solar_Program/821790

General Solar Information

Database of State Incentives for Renewables & Efficiency (DSIRE) -

<http://www.irecusa.org/irec-programs/dsire/>

Pennsylvania Sunshine Grant program -

http://www.portal.state.pa.us/portal/server.pt/community/grants_loans_tax_credits/10395/PA_Sunshine_Solar_Program/821790

Power Purchase Agreements – <http://www.epa.gov/greenpower/buygp/solarpower.htm>

The Solarize Guidebook: A Community Guide to Collective Purchasing of Residential PV Systems - details how communities can seize volume discounts through collective solar purchasing. <http://www.nrel.gov/docs/fy12osti/54738.pdf>

Find Solar – Basic information about solar energy and about buying solar -

<http://www.findsolar.org/>

Solar Energy Resource Center: Resources and best practices to implement solar, including articles, case studies, fact sheets, how-to guides, model rules and ordinances, presentations, sample government documents, technical reports, tools, and webinars. http://www4.eere.energy.gov/solar/sunshot/resource_center/

U.S. Department of Energy SunShot Program -
<http://www1.eere.energy.gov/solar/sunshot/index.html>

National Center for Photovoltaics - <http://www.nrel.gov/ncpv/>

Solar Industry

Solar Energy Industries Association - <http://www.seia.org/>

Solar Foundation - <http://thesolarfoundation.org/>

VoteSolar - <http://votesolar.org/>

American Solar Energy Society - <http://ases.org/>

Interstate Renewable Energy Council - <http://www.irecusa.org/>



Solar PV System Components

A Solar PV system may seem complicated, but in reality most systems are made up of just a few components.

Solar Panels

These are the primary component of a PV system. Many solar cells are arranged into a single panel contained within a frame. Each panel will have specific wattage rating. You may hear an installer refer to “230 watt rated panel”. This means that each panel has the ability to turn out 230 watts per hour under peak operating conditions.



Courtesy, EECO Center, Pittsburgh PA

Solar Array

This refers to a collection of many solar panels in a single installation. An array can have hundreds of panels or just a few. The entire array has a cumulative rating, usually represented in kilowatts. You may hear an installer refer to your system as a 5.5 Kilowatt system.



Courtesy, Joe Ison

Ground Mounted System

Some home owners opt to have a ground mounted system installed. All companies offer this option. You will often need a larger piece of property to use this option, but you will avoid issues of roof age and it may allow you to have a larger system.



Courtesy, Dan Brenner

Racking System

This refers to the metal mounts that will be used to support the installation. The racking system is also what attaches the panels to your roof. Many years ago, a solar installer would have a racking system custom built out of welded steel. Today there are dozens of companies that design standard engineered racking systems for all kinds of mounting needs. These systems go through rigorous testing and have very specific installation instructions.

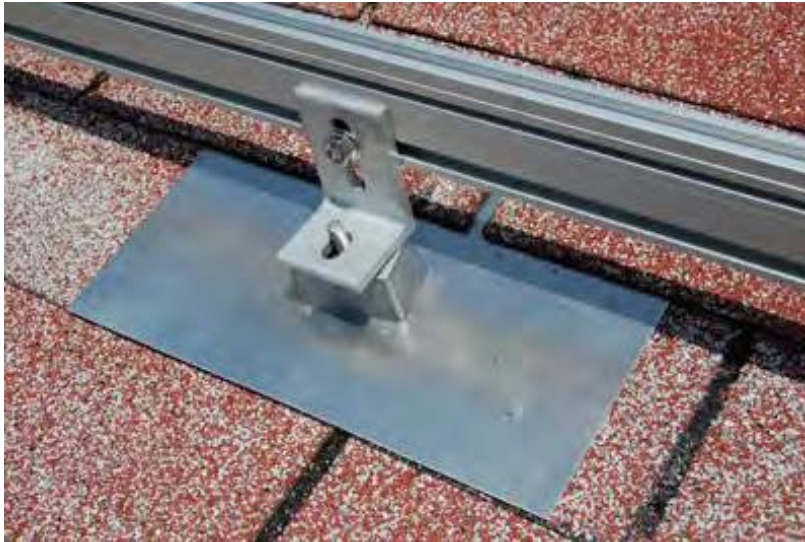

Courtesy Adam Solar Resources, www.adamsolarresources.com

Inverters

An inverter is a very important part of any PV installation. An inverter looks sort of like an electrical box. Its job is to convert the electricity that comes off the panels from DC (Direct Current) to AC (Alternating Current). Our entire electrical grid and all the appliances in our home can only use AC (Alternating Current), so it's essential to convert the electricity from DC to AC. The inverter can also represent a good portion of the cost of a PV system. About 20% of the cost of the entire system comes from the inverter. Inverters will usually need to be replaced every 15 years.



Courtesy of the Edmonds Family

Micro Inverters

Sometimes a smaller inverter is included on the back of a solar panel instead of one large inverter unit. This technology is known as Micro Inverter technology. There are several installers in the area that offer this technology. The benefits of micro inverter technology include higher efficiency, and a lower replacement cost.



Courtesy of Adam Solar Resources, Bridgeville PA

Bi-Directional Meter

Because Pennsylvania law provides for net-metering, you may be required to upgrade your meter to a bi-directional electric meter. This meter spins backwards when your solar system is feeding into the grid.

Smart Meter

Instead of a bi-directional meter, an electric company may suggest you upgrade to a Smart Meter. This type of meter monitors whether you're using electricity or feeding back to the grid, same as a bi-directional meter. It has the added ability of reporting your usage to the electric company automatically.



Courtesy, Dennis Tulenko

Interconnection

You will hear your installer refer to interconnection often. This term refers to the point at which the installation process is complete, the system has been inspected and is ready to be “interconnected” to the grid. This portion must be completed by a representative from your electric company. Your installer will often arrange this.

Disconnect Switch or Box

This is a safety feature that isolates certain portions of a solar PV system at the flip of a switch. These switches allow maintenance to be performed safely. In the case of a fire or other emergency, a first responder will also use the disconnect switches. There will be at least two clearly marked disconnect switches. They will usually be between the panels and the inverter, and between the inverter and your home's breaker box.



Courtesy, Edmonds Family

Combiner Box

This is a type of junction box that combines all the electrical output from multiple solar panels into a single circuit.



Credit Joe Morinville, www.eissolar.com

All of these components will come together to make up your solar installation. A solar installer may have several different configurations of these components, depending on your needs, but it's likely that your complete system will look something like this.

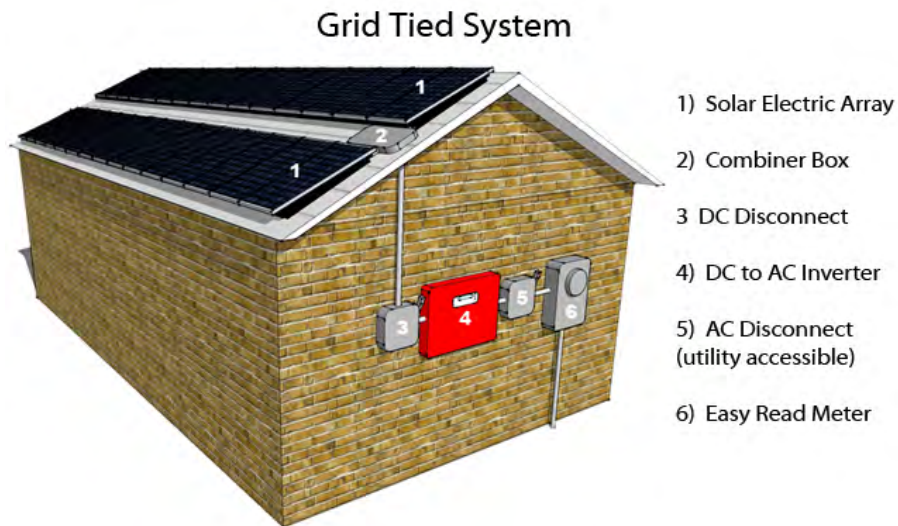

Diagram courtesy of Green Mountaintop Greene Energy, www.solarcatskills.com

Sample Diagrams



NOTES FOR STANDARD STRING SYSTEM ELECTRICAL DIAGRAM

PV MODULE RATINGS @ STC (Guide Section 5)

MODULE MAKE	
MODULE MODEL	
MAX POWER-POINT CURRENT (I_{MP})	A
MAX POWER-POINT VOLTAGE (V_{MP})	V
OPEN-CIRCUIT VOLTAGE (V_{OC})	V
SHORT-CIRCUIT CURRENT (I_{SC})	A
MAX SERIES FUSE (OCPD)	A
MAXIMUM POWER (P_{MAX})	W
MAX VOLTAGE (TYP 600V _{DC})	V
VOC TEMP COEFF (mV/°C <input type="checkbox"/> or %/°C <input type="checkbox"/>)	
IF COEFF SUPPLIED, CIRCLE UNITS	

NOTES FOR ALL DRAWINGS:

OCPD = OVERCURRENT PROTECTION DEVICE
 NATIONAL ELECTRICAL CODE® REFERENCES
 SHOWN AS (NEC XXXXX)

INVERTER RATINGS (Guide Section 4)

INVERTER MAKE	
INVERTER MODEL	
MAX DC VOLT RATING	V
MAX POWER @ 40°C	W
NOMINAL AC VOLTAGE	V
MAX AC CURRENT	A
MAX OCPD RATING	A

SIGNS--SEE GUIDE SECTION 7

SIGN FOR DC DISCONNECT

PHOTOVOLTAIC POWER SOURCE	
RATED MPP CURRENT	A
RATED MPP VOLTAGE	V
MAX SYSTEM VOLTAGE	V
MAX CIRCUIT CURRENT	A

WARNING: ELECTRICAL SHOCK HAZARD--LINE AND LOAD MAY BE ENERGIZED IN OPEN POSITION

SIGN FOR INVERTER OCPD AND AC DISCONNECT (IF USED)

SOLAR PV SYSTEM AC POINT OF CONNECTION	
AC OUTPUT CURRENT	A
NOMINAL AC VOLTAGE	V

THIS PANEL FED BY MULTIPLE SOURCES (UTILITY AND SOLAR)

NOTES FOR ARRAY CIRCUIT WIRING (Guide Section 6 and 8 and Appendix D):

- 1) LOWEST EXPECT AMBIENT TEMPERATURE BASED ON ASHRAE MINIMUM MEAN EXTREME DRY BULB TEMPERATURE FOR ASHRAE LOCATION MOST SIMILAR TO INSTALLATION LOCATION. LOWEST EXPECTED AMBIENT TEMP _____ °C
- 2) HIGHEST CONTINUOUS AMBIENT TEMPERATURE BASED ON ASHRAE HIGHEST MONTH 2% DRY BULB TEMPERATURE FOR ASHRAE LOCATION MOST SIMILAR TO INSTALLATION LOCATION. HIGHEST CONTINUOUS TEMPERATURE _____ °C
- 2) 2005 ASHRAE FUNDAMENTALS 2% DESIGN TEMPERATURES DO NOT EXCEED 47°C IN THE UNITED STATES (PALM SPRINGS, CA IS 44.1°C). FOR LESS THAN 9 CURRENT-CARRYING CONDUCTORS IN ROOF-MOUNTED SUNLIT CONDUIT AT LEAST 0.5' ABOVE ROOF AND USING THE OUTDOOR DESIGN TEMPERATURE OF 47°C OR LESS (ALL OF UNITED STATES),
 - a) 12 AWG, 90°C CONDUCTORS ARE GENERALLY ACCEPTABLE FOR MODULES WITH 1sc OF 7.68 AMPS OR LESS WHEN PROTECTED BY A 12-AMP OR SMALLER FUSE.
 - b) 10 AWG, 90°C CONDUCTORS ARE GENERALLY ACCEPTABLE FOR MODULES WITH 1sc OF 9.6 AMPS OR LESS WHEN PROTECTED BY A 15-AMP OR SMALLER FUSE.

NOTES FOR INVERTER CIRCUITS (Guide Section 8 and 9):

- 1) IF UTILITY REQUIRES A VISIBLE-BREAK SWITCH, DOES THIS SWITCH MEET THE REQUIREMENT? YES NO N/A
- 2) IF GENERATION METER REQUIRED, DOES THIS METER SOCKET MEET THE REQUIREMENT? YES NO N/A
- 3) SIZE PHOTOVOLTAIC POWER SOURCE (DC) CONDUCTORS BASED ON MAX CURRENT ON NEC 690.53 SIGN OR OCPD RATING AT DISCONNECT
- 4) SIZE INVERTER OUTPUT CIRCUIT (AC) CONDUCTORS ACCORDING TO INVERTER OCPD AMPERE RATING. (See Guide Section 9)
- 5) TOTAL OF _____ INVERTER OCPD(S) ONE FOR EACH INVERTER. DOES TOTAL SUPPLY BREAKERS COMPLY WITH 120% BUSBAR EXCEPTION IN 690.64(B)(2)(a)? YES NO

Contractor Name,
Address and Phone

Notes for One-Line Standard Electrical Diagram for Single-Phase PV Systems

Site Name: _____
 Site Address: _____
 System AC Size: _____

Drawn By: _____	SIZE	FSCM NO	DWG NO	REV
Checked By: _____	SCALE	NTS	Date:	SHEET

STANDARD STRING SYSTEM SYSTEM ELECTRICAL DIAGRAM

EQUIPMENT SCHEDULE			
TAG	DESCRIPTION	PART NUMBER	NOTES
1	SOLAR PV MODULE		
2	PV ARRAY		
3	J-BOX (IF USED)		
4	COMBINER (IF USED)		
5	DC DISCONNECT		
6	DC/AC INVERTER		
7	GEN METER (IF USED)		
8	AC DISCONNECT (IF USED)		
9	SERVICE PANEL		

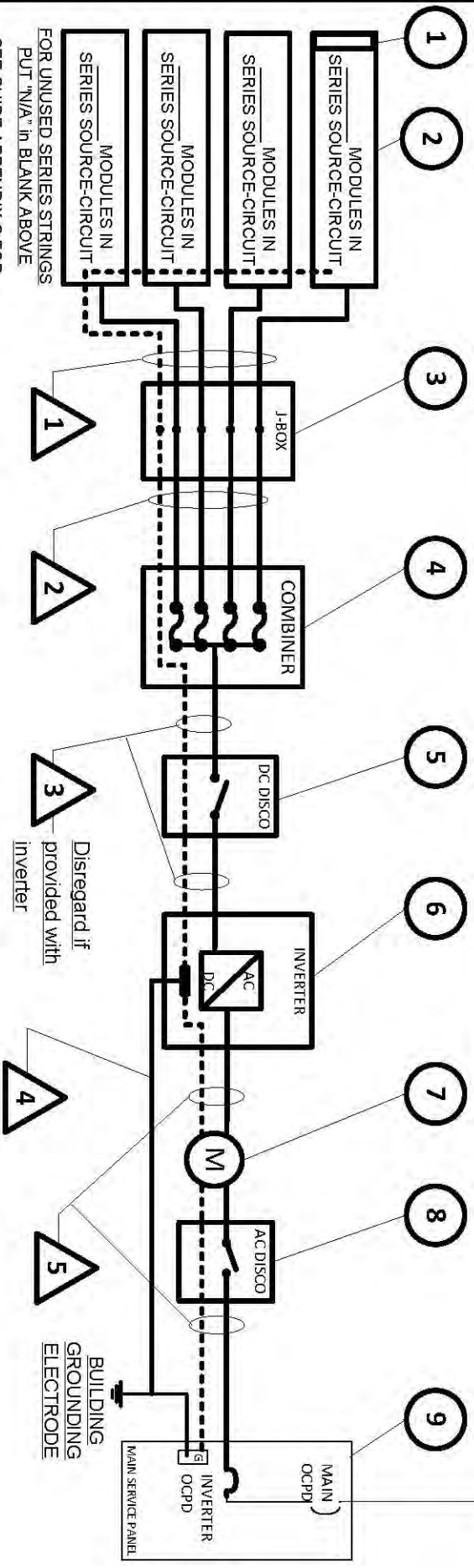
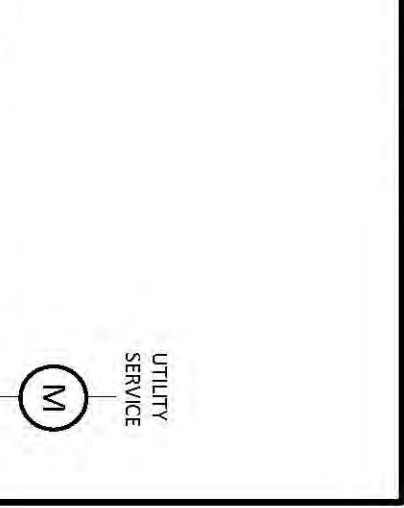

TAG	DESCRIPTION OR CONDUCTOR TYPE	COND. GAUGE	NUMBER OF CONDUCTORS	CONDUIT TYPE	CONDUIT SIZE
1	USE-2 <input type="checkbox"/> or PV WIRE <input type="checkbox"/>			N/A	N/A
2	BARE COPPER EQ. GRD. COND. (EGC)			N/A	N/A
3	THWN-2 <input type="checkbox"/> or XHHW-2 <input type="checkbox"/> or RHW-2 <input type="checkbox"/>			N/A	N/A
4	THWN-2 <input type="checkbox"/> or XHHW-2 <input type="checkbox"/> or RHW-2 <input type="checkbox"/>				
5	INSULATED EGC				
6	THWN-2 <input type="checkbox"/> or XHHW-2 <input type="checkbox"/> or RHW-2 <input type="checkbox"/>				
7	INSULATED EGC				

CONDUIT AND CONDUCTOR SCHEDULE					
TAG	DESCRIPTION OR CONDUCTOR TYPE	COND. GAUGE	NUMBER OF CONDUCTORS	CONDUIT TYPE	CONDUIT SIZE
1	USE-2 <input type="checkbox"/> or PV WIRE <input type="checkbox"/>			N/A	N/A
2	BARE COPPER EQ. GRD. COND. (EGC)			N/A	N/A
3	THWN-2 <input type="checkbox"/> or XHHW-2 <input type="checkbox"/> or RHW-2 <input type="checkbox"/>			N/A	N/A
4	THWN-2 <input type="checkbox"/> or XHHW-2 <input type="checkbox"/> or RHW-2 <input type="checkbox"/>				
5	INSULATED EGC				

Contractor Name: _____
 Address and Phone: _____

Site Name: _____
 Site Address: _____
 System AC Size: _____

Drawn By: _____
 Checked By: _____

SIZE: _____ FSCM NO: _____ DWG NO: _____ REV: _____

SCALE: _____ NTS: _____ Date: _____ SHEET: _____

STANDARD STRING SYSTEM SITE PLAN

Contractor Name: Address and Phone:		Site Plan for Small-Scale, Single-Phase PV Systems			
Drawn By:					
Checked By:		SIZE	FSCM NO	DWG/NO	REV
		SCALE	NTS	Date:	SHEET

NOTES FOR MICRO-INVERTER ELECTRICAL DIAGRAM

PV MODULE RATINGS @ STC (Guide Section 5)

MODULE MAKE	
MODULE MODEL	
MAX POWER-POINT CURRENT (I _{mp})	
MAX POWER-POINT VOLTAGE (V _{mp})	
OPEN-CIRCUIT VOLTAGE (V _{oc})	
SHORT-CIRCUIT CURRENT (I _{sc})	
MAX SERIES FUSE (OCPPD)	
MAXIMUM POWER (P _{max})	
MAX VOLTAGE (TYP 600V _{DC})	
VOC TEMP COEFF (mV/°C <input type="checkbox"/> or %/°C <input type="checkbox"/>)	
IF COEFF SUPPLIED, CIRCLE UNITS	

NOTES FOR ALL DRAWINGS:

OCPPD = OVERCURRENT PROTECTION DEVICE
 NATIONAL ELECTRICAL CODE® REFERENCES
 SHOWN AS (NEC XXX.XX)

INVERTER RATINGS (Guide Section 4)

INVERTER MAKE	
INVERTER MODEL	
MAX DC VOLT RATING	
MAX POWER @ 40°C	
NOMINAL AC VOLTAGE	
MAX AC CURRENT	
MAX OCPD RATING	

SIGNS-SEE GUIDE SECTION 7

SIGN FOR DC DISCONNECT

No sign necessary since 690.51 marking on PV module covers needed information

SIGN FOR INVERTER OCPD AND AC DISCONNECT (IF USED)

SOLAR PV SYSTEM	
AC POINT OF CONNECTION	
AC OUTPUT CURRENT	
NOMINAL AC VOLTAGE	
THIS PANEL FED BY MULTIPLE SOURCES (UTILITY AND SOLAR)	

NOTES FOR ARRAY CIRCUIT WIRING (Guide Section 6 and 8 and Appendix E):

- 1) LOWEST EXPECT AMBIENT TEMPERATURE BASED ON ASHRAE MINIMUM MEAN EXTREME DRY BULB TEMPERATURE FOR ASHRAE LOCATION MOST SIMILAR TO INSTALLATION LOCATION. LOWEST EXPECTED AMBIENT TEMP ____ °C
- 2) HIGHEST CONTINUOUS AMBIENT TEMPERATURE BASED ON ASHRAE HIGHEST MONTH 2% DRY BULB TEMPERATURE FOR ASHRAE LOCATION MOST SIMILAR TO INSTALLATION LOCATION. HIGHEST CONTINUOUS TEMPERATURE ____ °C
- 2) 2009 ASHRAE FUNDAMENTALS 2% DESIGN TEMPERATURES DO NOT EXCEED 47°C IN THE UNITED STATES (PALM SPRINGS, CA IS 44.1°C). FOR LESS THAN 9 CURRENT-CARRYING CONDUCTORS IN ROOF-MOUNTED SUNLIT CONDUIT AT LEAST 0.5' ABOVE ROOF AND USING THE OUTDOOR DESIGN TEMPERATURE OF 47°C OR LESS (ALL OF UNITED STATES).
 - a) 12 AWG, 90°C CONDUCTORS ARE GENERALLY ACCEPTABLE FOR MODULES WITH I_{sc} OF 7.68 AMPS OR LESS WHEN PROTECTED BY A 12-AMP OR SMALLER FUSE.
 - b) 10 AWG, 90°C CONDUCTORS ARE GENERALLY ACCEPTABLE FOR MODULES WITH I_{sc} OF 9.6 AMPS OR LESS WHEN PROTECTED BY A 15-AMP OR SMALLER FUSE.

NOTES FOR INVERTER CIRCUITS (Guide Section 8 and 9):

- 1) IF UTILITY REQUIRES A VISIBLE-BREAK SWITCH, DOES THIS SWITCH MEET THE REQUIREMENT? YES NO N/A
- 2) IF GENERATION METER REQUIRED, DOES THIS METER SOCKET MEET THE REQUIREMENT? YES NO N/A
- 3) SIZE PHOTOVOLTAIC POWER SOURCE (DC) CONDUCTORS BASED ON MAX CURRENT ON NEC 690.53 SIGN OR OCPD RATING AT DISCONNECT
- 4) SIZE INVERTER OUTPUT CIRCUIT (AC) CONDUCTORS ACCORDING TO INVERTER OCPD AMPERE RATING. (See Guide Section 9)
- 5) TOTAL OF _____ INVERTER OUTPUT CIRCUIT OCPD(S), ONE FOR EACH MICRO-INVERTER CIRCUIT. DOES TOTAL SUPPLY BREAKERS COMPLY WITH 120% BUSBAR EXCEPTION IN 690.64(B)(2)(a)? YES NO

Contractor Name:
Address and Phone:

Notes for One-Line Standard Electrical
 Diagram for Single-Phase PV Systems

Site Name:
 Site Address:
 System AC Size:

Drawn By:	SIZE	FSOIM NO.	DWG NO.	REV
Checked by:	SCALE	NTS	Date:	SHEET

MICRO-INVERTER ELECTRICAL DIAGRAM

EQUIPMENT SCHEDULE

○ TAG	DESCRIPTION	PART NUMBER	NOTES
1	PV DC or AC MODULE		
2	DC/AC INVERTER (MICRO)		
3	J-BOX (IF USED)		
4	PV ARRAY		
5	AC COMB. PANEL (IF USED)		
6	GEN METER (IF USED)		
7	AC DISCONNECT (IF USED)		
8	SERVICE PANEL		

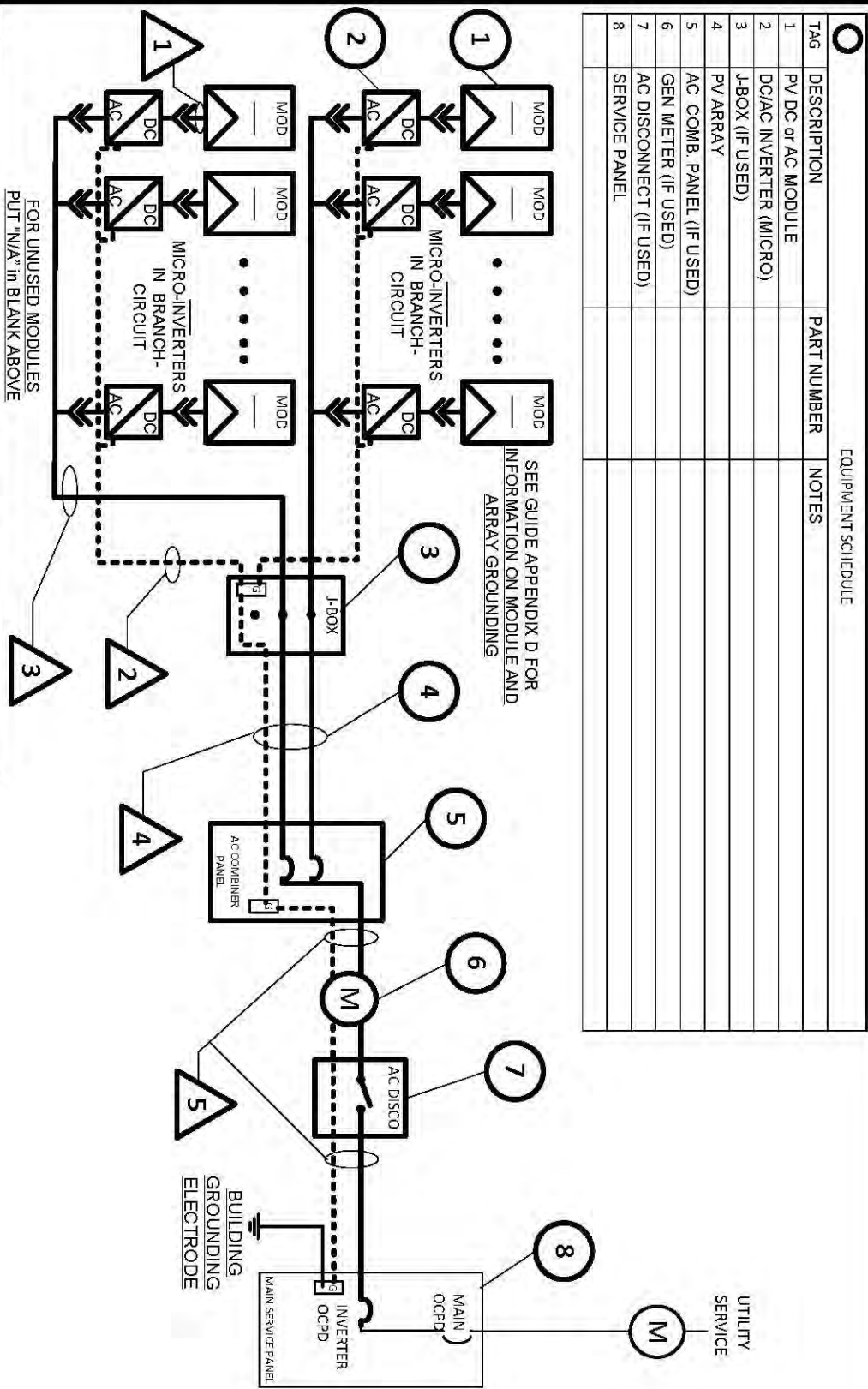

CONDUIT AND CONDUCTOR SCHEDULE

△ TAG	DESCRIPTION OR CONDUCTOR TYPE	COND.	NUMBER OF CONDUCTORS	CONDUIT TYPE	CONDUIT SIZE
1	USE-2-□ or PV WIRE □	GAUGE	MFG Cable	N/A	N/A
2	GEC □ EGC □ X ALL THAT APPLY	MFG	MFG Cable	N/A	N/A
3	EXTERIOR CABLE LISTED W/ INV.	MFG	MFG Cable	N/A	N/A
4	THWN-2 □ or XHHW-2 □ or RHW-2 □	MFG	MFG Cable	N/A	N/A
	GEC □ EGC □ X ALL THAT APPLY			SAME	SAME
	NO DC GEC IF 690.35 SYSTEM				
5	THWN-2 □ or XHHW-2 □ or RHW-2 □			SAME	SAME
	GEC □ EGC □ X ALL THAT APPLY			SAME	SAME

One-Line Standard Electrical Diagram for Micro-Inverter PV Systems

Contractor Name: _____
Address and Phone: _____

Site Name: _____
Site Address: _____
System AC Size: _____

Drawn By: _____
Checked By: _____

Scale: _____ NTS _____ Date: _____

SIZE _____ FSCM NO _____ DWG NO _____ REV _____

MICRO-INVERTER SITE PLAN

Contractor Name, Address and Phone:		Site Plan for Small-Scale, Single-Phase PV Systems	
Drawn By:	SIZE	Site Name:	DWG NO
	ESCAL NO	Site Address:	
Checked By:	System AC Size:	Date:	REV
	SCALE	NTS	SHEET

NOTES FOR AC MODULE DIAGRAM

NOTES FOR ALL DRAWINGS:

OCPD = OVERCURRENT PROTECTION DEVICE
 NATIONAL ELECTRICAL CODE® REFERENCES
 SHOWN AS (NEC XXX.XX)

AC MODULE RATINGS (Guide Appendix C)

AC MODULE MAKE	
AC MODULE MODEL	
NOMINAL OPERATING AC VOLTAGE	
NOMINAL OPERATING AC FREQUENCY	
MAXIMUM AC POWER	
MAXIMUM AC CURRENT	
MAXIMUM OCPD RATING	

SIGNS--SEE GUIDE SECTION 7

SIGN FOR DC DISCONNECT

N/A since no dc wiring

SIGN FOR INVERTER OCPD AND AC DISCONNECT (IF USED)

SOLAR PV SYSTEM
 AC POINT OF CONNECTION

AC OUTPUT CURRENT	
NOMINAL AC VOLTAGE	
THIS PANEL FED BY MULTIPLE SOURCES (UTILITY AND SOLAR)	

NOTES FOR ARRAY CIRCUIT WIRING (Guide Section 6 and 8 and Appendix F):

- 1) LOWEST EXPECT AMBIENT TEMPERATURE BASED ON ASHRAE MINIMUM MEAN EXTREME DRY BULB TEMPERATURE FOR ASHRAE LOCATION MOST SIMILAR TO INSTALLATION LOCATION. LOWEST EXPECTED AMBIENT TEMP ____°C
- 2) HIGHEST CONTINUOUS AMBIENT TEMPERATURE BASED ON ASHRAE HIGHEST MONTH 2% DRY BULB TEMPERATURE FOR ASHRAE LOCATION MOST SIMILAR TO INSTALLATION LOCATION. HIGHEST CONTINUOUS TEMPERATURE ____°C
- 2) 2009 ASHRAE FUNDAMENTALS 5.2% DESIGN TEMPERATURES DO NOT EXCEED 47°C IN THE UNITED STATES (PALM SPRINGS, CA IS 44.1°C). FOR 6 OR LESS CURRENT-CARRYING CONDUCTORS IN ROOF-MOUNTED SUNLIT CONDUIT AT LEAST 0.5" ABOVE ROOF AND USING THE OUTDOOR DESIGN TEMPERATURE OF 47°C OR LESS (ALL OF UNITED STATES),
 - a) 12 AWG, 90°C CONDUCTORS ARE GENERALLY ACCEPTABLE FOR AC MODULES INVERTER OUTPUT CIRCUITS WITH 12 AMPS OR LESS WHEN PROTECTED BY A 15-AMP OR SMALLER OCPD.
 - b) 10 AWG, 90°C CONDUCTORS ARE GENERALLY ACCEPTABLE FOR AC MODULES INVERTER OUTPUT CIRCUITS WITH 16 AMPS OR LESS WHEN PROTECTED BY A 20-AMP OR SMALLER OCPD.

NOTES FOR INVERTER CIRCUITS (Guide Section 8 and 9):

- 1) IF UTILITY REQUIRES A VISIBLE-BREAK SWITCH, DOES THIS SWITCH MEET THE REQUIREMENT? YES NO N/A
- 2) IF GENERATION METER REQUIRED, DOES THIS METER SOCKET MEET THE REQUIREMENT? YES NO N/A
- 3) SIZE PHOTOVOLTAIC POWER SOURCE (DC) CONDUCTORS BASED ON MAX CURRENT ON NEC 690.53 SIGN OR OCPD RATING AT DISCONNECT (N/A)
- 4) SIZE INVERTER OUTPUT CIRCUIT (AC) CONDUCTORS ACCORDING TO INVERTER OCPD AMPERE RATING. (See Guide Section 9)
- 5) TOTAL OF _____ INVERTER OUTPUT CIRCUIT OCPD(S). ONE FOR EACH AC MODULE CIRCUIT DOES TOTAL SUPPLY BREAKERS COMPLY WITH 120% BUSBAR EXCEPTION IN 690.64(B)(2)(a)? YES NO

Notes for One-Line Standard Electrical Diagram for Single-Phase PV Systems

Contractor Name:
 Address and Phone:

Site Name:
 Site Address:
 System AC Size:

Drawn By:	SIZE	FSCM NO	DWG NO	REV
Checked By:	SCALE	NTS	Date:	SHEET

AC MODULE ELECTRICAL DIAGRAM

EQUIPMENT SCHEDULE

○ TAG	DESCRIPTION	PART NUMBER	NOTES
1			
2			
3			
4			
5			
6			
7			

SEE GUIDE APPENDIX D FOR INFORMATION ON MODULE AND ARRAY GROUNDING

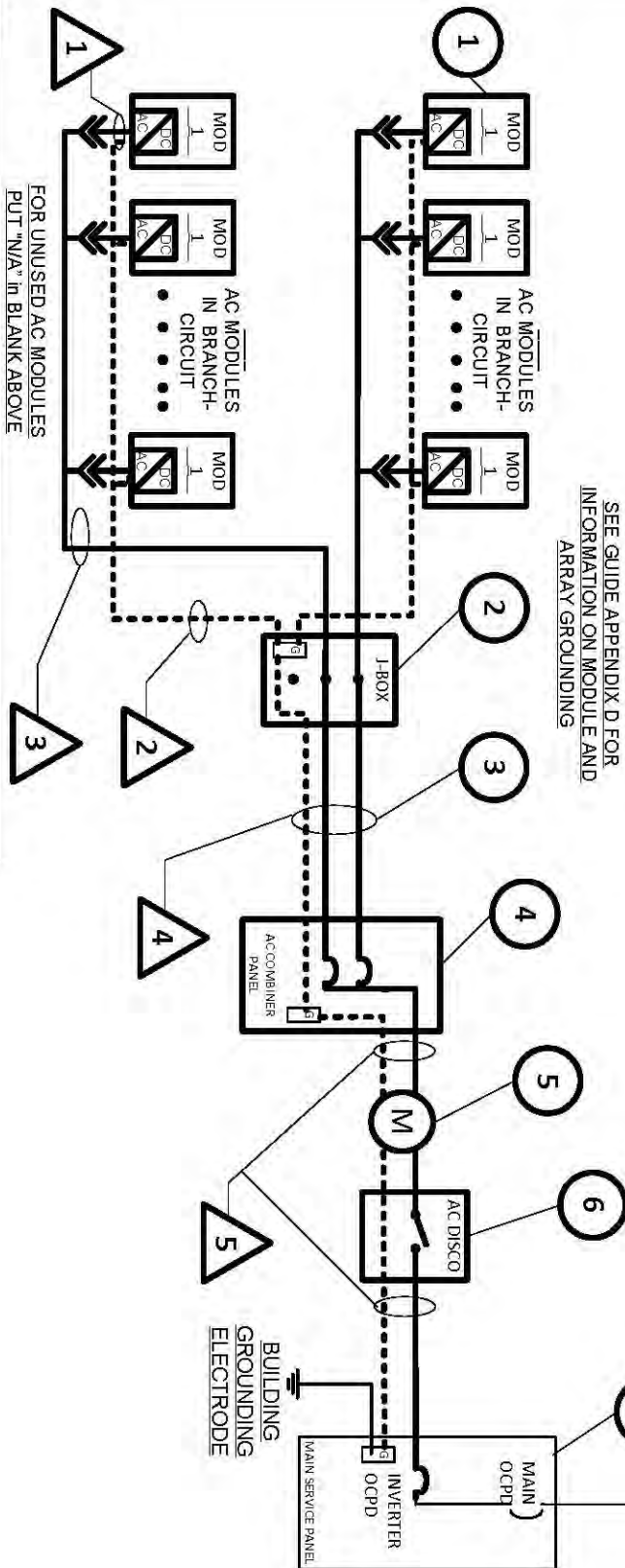

CONDUIT AND CONDUCTOR SCHEDULE

△ TAG	DESCRIPTION OR CONDUCTOR TYPE	COND. GAUGE	NUMBER OF CONDUCTORS	CONDUIT TYPE	CONDUIT SIZE
1	USE 2-□ or PV WIRE □	MFG	MFG Cable	N/A	N/A
2	GEC □ EGC □ X ALL THAT APPLY	MFG	MFG Cable	N/A	N/A
3	EXTERIOR CABLE LISTED w/ INV.	MFG	MFG Cable	N/A	N/A
4	THWN-2 □ or XHHW-2 □ or RHW-2 □				
	GEC □ EGC □ X ALL THAT APPLY				
	NO DC GEC IF 690.35 SYSTEM				
5	THWN-2 □ or XHHW-2 □ or RHW-2 □				
	GEC □ EGC □ X ALL THAT APPLY				

Contractor Name,
Address and Phone:

One-Line Standard Electrical Diagram
for AC Module PV Systems

Site Name:
Site Address:
System AC Size:

Drawn By:

SIZE

FSDM NO

DWG NO

REV

Checked By:

SCALE

NTS

Date:

SHEET

AC MODULE SITE PLAN

Contractor Name, Address and Phone:		Site Plan for Small-Scale, Single-Phase PV Systems			
Drawn By: _____					
Checked By: _____		SIZE	FSCM NO	DWG/NO	REV
SCALE		NTS	Date:	SHEET	

NOTES FOR SUPPLY-SIDE CONNECTION ELECTRICAL DIAGRAM

PV MODULE RATINGS @ STC (Guide Section 5)

MODULE MAKE	
MODULE MODEL	
MAX POWER-POINT CURRENT (I_{MP})	A
MAX POWER-POINT VOLTAGE (V_{MP})	V
OPEN-CIRCUIT VOLTAGE (V_{OC})	V
SHORT-CIRCUIT CURRENT (I_{SC})	A
MAX SERIES FUSE (OCPD)	A
MAXIMUM POWER (P_{MAX})	W
MAX VOLTAGE (TYP 600V _{DC})	V
VOC TEMP COEFF (mV/°C <input type="checkbox"/> or %/°C <input type="checkbox"/>)	
IF COEFF SUPPLIED, CIRCLE UNITS	

NOTES FOR ALL DRAWINGS:

OCPD = OVERCURRENT PROTECTION DEVICE
 NATIONAL ELECTRICAL CODE® REFERENCES
 SHOWN AS (NEC XXXXX)

INVERTER RATINGS (Guide Section 4)

INVERTER MAKE	
INVERTER MODEL	
MAX DC VOLT RATING	V
MAX POWER @ 40°C	W
NOMINAL AC VOLTAGE	V
MAX AC CURRENT	A
MAX OCPD RATING	A

SIGNS--SEE GUIDE SECTION 7

SIGN FOR DC DISCONNECT

PHOTOVOLTAIC POWER SOURCE	
RATED MPP CURRENT	A
RATED MPP VOLTAGE	V
MAX SYSTEM VOLTAGE	V
MAX CIRCUIT CURRENT	A

WARNING: ELECTRICAL SHOCK
 HAZARD--LINE AND LOAD MAY BE
 ENERGIZED IN OPEN POSITION

SIGN FOR INVERTER OCPD AND AC DISCONNECT (IF USED)

SOLAR PV SYSTEM AC POINT OF CONNECTION	
AC OUTPUT CURRENT	A
NOMINAL AC VOLTAGE	V

THIS PANEL FED BY MULTIPLE
 SOURCES (UTILITY AND SOLAR)

NOTES FOR ARRAY CIRCUIT WIRING (Guide Section 6 and 8 and Appendix D):

- 1) LOWEST EXPECT AMBIENT TEMPERATURE BASED ON ASHRAE MINIMUM MEAN EXTREME DRY BULB TEMPERATURE FOR ASHRAE LOCATION MOST SIMILAR TO INSTALLATION LOCATION. LOWEST EXPECTED AMBIENT TEMP _____ °C
- 2) HIGHEST CONTINUOUS AMBIENT TEMPERATURE BASED ON ASHRAE HIGHEST MONTH 2% DRY BULB TEMPERATURE FOR ASHRAE LOCATION MOST SIMILAR TO INSTALLATION LOCATION. HIGHEST CONTINUOUS TEMPERATURE _____ °C
- 2) 2005 ASHRAE FUNDAMENTALS 2% DESIGN TEMPERATURES DO NOT EXCEED 47°C IN THE UNITED STATES (PALM SPRINGS, CA IS 44.1°C). FOR LESS THAN 9 CURRENT-CARRYING CONDUCTORS IN ROOF-MOUNTED SUNLIT CONDUIT AT LEAST 0.5' ABOVE ROOF AND USING THE OUTDOOR DESIGN TEMPERATURE OF 47°C OR LESS (ALL OF UNITED STATES),
 - a) 12 AWG, 90°C CONDUCTORS ARE GENERALLY ACCEPTABLE FOR MODULES WITH I_{sc} OF 7.68 AMPS OR LESS WHEN PROTECTED BY A 12-AMP OR SMALLER FUSE.
 - b) 10 AWG, 90°C CONDUCTORS ARE GENERALLY ACCEPTABLE FOR MODULES WITH I_{sc} OF 9.6 AMPS OR LESS WHEN PROTECTED BY A 15-AMP OR SMALLER FUSE.

NOTES FOR INVERTER CIRCUITS (Guide Section 8 and 9):

- 1) IF UTILITY REQUIRES A VISIBLE-BREAK SWITCH, DOES THIS SWITCH MEET THE REQUIREMENT? YES NO N/A
- 2) IF GENERATION METER REQUIRED, DOES THIS METER SOCKET MEET THE REQUIREMENT? YES NO N/A
- 3) SIZE PHOTOVOLTAIC POWER SOURCE (DC) CONDUCTORS BASED ON MAX CURRENT ON NEC 690.53 SIGN OR OCPD RATING AT DISCONNECT
- 4) SIZE INVERTER OUTPUT CIRCUIT (AC) CONDUCTORS ACCORDING TO INVERTER OCPD AMPERE RATING. (See Guide Section 9)
- 5) TOTAL OF _____ INVERTER OCPD(S) ONE FOR EACH INVERTER. DOES TOTAL SUPPLY BREAKERS COMPLY WITH 120% BUSBAR EXCEPTION IN 690.64(B)(2)(a)? YES NO

Contractor Name,
 Address and Phone

Notes for One-Line Standard Electrical Diagram for Single-Phase PV Systems

Site Name: _____
 Site Address: _____
 System AC Size: _____

Drawn By: _____	SIZE	FSCM NO	DWG NO	REV
Checked By: _____	SCALE	NTS	Date: _____	SHEET

SUPPLY-SIDE CONNECTION ELECTRICAL DIAGRAM

EQUIPMENT SCHEDULE

TAG	DESCRIPTION	PART NUMBER	NOTES
1			
2			
3			
4			
5			
6			
7			
8			
9			
10			

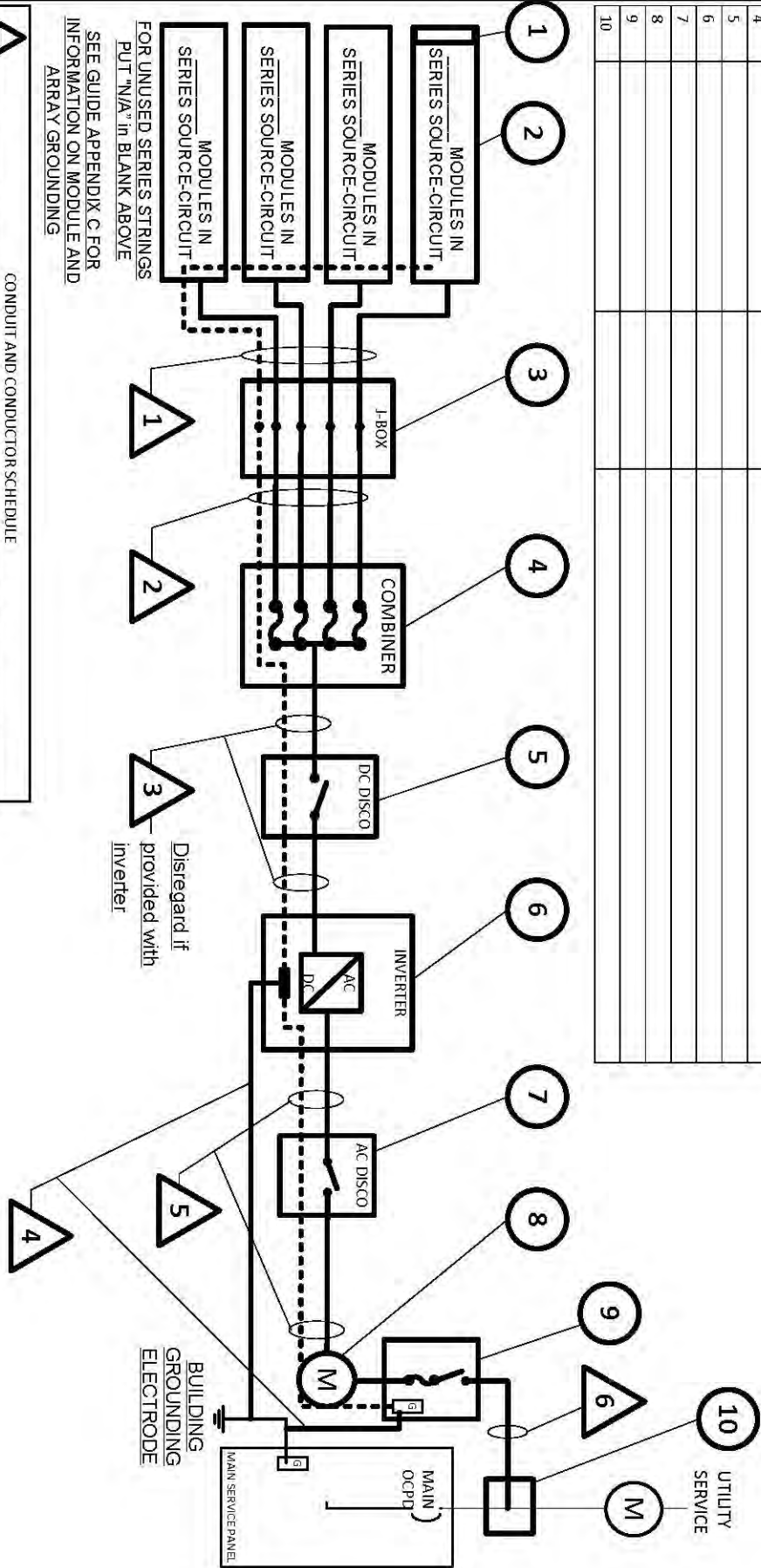

CONDUIT AND CONDUCTOR SCHEDULE

TAG	DESCRIPTION OR CONDUCTOR TYPE	COND. GAUGE	NUMBER OF CONDUCTORS	CONDUIT TYPE	CONDUIT SIZE
1	USE-2 <input type="checkbox"/> or PV WIRE <input type="checkbox"/>				
2	BARE COPPER EQ. GRD. COND. (EGC)				
3	THWN-2 <input type="checkbox"/> or XHHW-2 <input type="checkbox"/> or RHW-2 <input type="checkbox"/>				
4	THWN-2 <input type="checkbox"/> or XHHW-2 <input type="checkbox"/> or RHW-2 <input type="checkbox"/>				
5	THWN-2 <input type="checkbox"/> or XHHW-2 <input type="checkbox"/> or RHW-2 <input type="checkbox"/>				
6	THWN-2 <input type="checkbox"/> or XHHW-2 <input type="checkbox"/> or RHW-2 <input type="checkbox"/>				

Contractor Name, Address and Phone: _____

One-Line Electrical Diagram for Supply-Side Connected Single-Phase PV Systems

Site Name: _____

Site Address: _____

System AC Size: _____

Drawn By: _____

Checked By: _____

Scale: _____ NTS _____ Date: _____

Sheet _____ of _____

SUPPLY-SIDE CONNECTION SITE PLAN

Contractor Name, Address and Phone:		Site Plan for Small-Scale, Single-Phase PV Systems			
Drawn By: _____					
Checked By: _____		SIZE	F-SCM NO	DWG/NO	REV
SCALE		NTS	Date:	SHEET	

Sample Permit

Solar Photovoltaic (PV) Permit Application

Page 1 of 3

Applicability: This Solar Photovoltaic Permit Application may be used for systems with the following qualifications:

- A total inverter capacity with a continuous AC power output of 13,440 watts (13.44kW) or less;
- A distributed weight load of less than or equal to five (5) lbs. per sq. ft.;
- A point load of less than or equal to 45 lbs. per sq. ft.;
- Installation on a roof with a single layer of lightweight roofing material;
- A mounting structure with an engineered product designed to mount PV modules with no more than an 18" gap beneath the module frames;
- The installation is overseen by a trained solar professional and a licensed Pennsylvania contractor;
- The installer assumes liability for the installation and the roof structure as it pertains to the installation.

If the System does not meet any of the above qualifications or the answer is "NO" to any of the questions in Steps 1 and 2 below, the municipality may require further information or review as it deems appropriate.

Questions regarding this Application should be directed to: Elise Taylor at 412-555-555. Definitions of terms used in this Application and sample application documents can be found in the *Solar Guide for Municipalities*.

Materials needed upon permit application submission

1. A completed copy of this Solar Photovoltaic Permit Application.
2. A site plan showing location of major components on the property. This drawing need not be to scale, but it should represent relative location of components at site (A sample site plan is included in the *Guide*.)
3. A single-line electrical diagrams showing the configuration of the photovoltaic ("PV") array, the wiring system, the overcurrent protection, the inverter, the disconnects, any required signs, and the AC connection to the building.
4. Specification sheets and installation manuals (if available) for all manufactured components including, but not limited to, PV modules, inverter(s), combiner box, disconnects, and mounting system.
5. An application fee of \$ 250.

Basic Information

Brief System Description _____

(eg, number and power rating of panels; total power rating of system; panel and inverter manufacturer; inverter/microinverter output, location of system on property)

Address of Project: 529 Main St, Sunnyboro, PA

Applicant Name: Mary T. Moore

Address: 529 Main St, Sunnyboro, PA

Telephone Number: 412-555-555

E-mail address: mtm@ilovesolar.org

Installation Company (The System must be installed by a contractor licensed by the Commonwealth of Pennsylvania): Sun-Days Solar, Inc
Address: 222 Maple Lane, West Burlington, PA

Telephone Number: 724-555-555

E-mail address: info@sun-days.com

HIC#: XXXXXXXXXX

Property Owner (if different from the Applicant):

Name: _____

Address: _____

Telephone Number: _____

E-mail address: _____

Owner of Solar System (if different from Applicant or Property Owner):

Name: _____

Address: _____

Telephone Number: _____

E-mail address: _____



Solar Photovoltaic (PV) Permit Application

Page 2 of 3

Installer Qualification: The installation of the System will be overseen by (check one below):

- NABCEP certified solar equipment installer
- UL certified solar equipment installer
- Electrical contractor with a license accepted by the municipality
- Solar installer on the approved list for the Pennsylvania Sunshine grant program

Name of person with above qualification: Joe Jones

Step 1: Structural Review of PV Array Mounting System

A. Roof Information:

YES NO Does the roof have a single roof covering?

YES NO Is the roofing type lightweight (composition, lightweight masonry, metal, etc.)?

Roofing Material Description composition

Note: Roof structures supporting heavier roofing materials (e.g. slate, heavy masonry, tile) may not have the assumed dead loading and live loading capacities that are found with lighter weight roofing materials and may justify a further review to clarify whether the roof structure is either in compliance or needs enhancement.

YES NO Is weatherproofing sealant compatible with the roofing material. Describe method *and* type of weatherproofing roof penetrations (e.g. flashing, caulk) flashing

YES NO Has the installer conducted a visual inspection of the roof and confirmed that there is no pre-existing damage? (If damage is noted, provide details for any work necessary to repair the existing roof structure.)

B. Mounting System Information:

YES NO Is the mounting structure an engineered product designed to mount PV modules with no more than an 18" gap beneath the module frames? If YES, complete information on the mounting system below:

a. Mounting System Manufacturer OmniRack

Product Name and Model# ModMount 2.0

b. Total Weight of PV Modules and Rails 1780 lbs

c. Total Number of Attachment Points 48

d. Weight per Attachment Point (Total Weight of Modules and Rails (from line b.) ÷ Total Number of Attachment Points (from line c.) = 37 lbs.

YES NO Is the point load weight in line (d.) above, less than or equal to 45 lbs? If YES, complete the following:

e. Maximum Spacing Between Attachments Points on a Rail = 48 inches

(see product manual for maximum spacing allowed based on maximum design wind speed)

f. Total Surface Area of PV Modules (square feet) 674 ft².

g. Distributed Weight of PV Module on Roof (Total Weight of PV Modules and Rails (from line b.) ÷ Total Surface Area of PV Modules (from line f.) = 2.64 lbs/ft².

YES NO Is the distributed weight in line (g) above, less than or equal to 5 lbs/ft²?

Page 2 of 3; version October 31, 2012

Solar Photovoltaic (PV) Permit Application

Page 3 of 3

Step 2: Review of PV System (Calculations for Electrical Diagram)

- YES NO 1. The total inverter capacity has a continuous AC power output of 13,440 Watts or less?
- YES NO 2. PV modules, utility-interactive inverters, and combiner boxes are identified for use in PV systems.
- YES NO 3. The PV array is composed of 4 series strings or less per inverter.
- YES NO 4. The AC interconnection point is on the load side of service disconnecting means.
- YES NO 5. Can one of the four standard electrical diagrams (standard string system, micro-inverter, AC Module or Supply-Side Connection systems) be used to accurately represent the PV system? (refer to *Guide*)

Step 3: Inspection of PV System

1. A Pennsylvania certified electrical inspector (the "Inspector") must conduct an on-site inspection of the System.
2. The Inspector must verify the accuracy of the information provided in Steps 1 and 2 above.
3. The Inspector must execute the below verification of the inspection of the System and submit approval to municipality.

Certification of the Designated Representative of the Solar Installation Company

I, Joe Jones, on behalf of Sun-Days Solar, Inc. (the "Company") hereby represent and warrant that:

- (a) The information provided in this permit application is accurate and complete to the best of my knowledge;
- (b) The building and its roof are structurally capable of supporting the System; and
- (c) The System will be designed and installed in compliance with the applicable requirements of the Pennsylvania Uniform Construction Code, National Electric Code and other applicable construction codes.

The Company hereby assumes all liability associated with the installation of this System, including any liability arising out of or resulting from the roof supporting the System, and shall indemnify, defend and hold harmless and its employees and third party inspectors from and against any claims referring or relating to (1) the accuracy of any information, representation or statement made in this Application; or (2) the representations and warranties made in this Certification.

I have been duly designated by the Company to execute this certification on its behalf.

Installation Company: Sun-Days Solar, Inc.

Installer/Company Representative Name: Joe Jones

Signature:  Date: 11/13/12

For Electrical Inspector: I have inspected this system installation and have verified to the best of my ability that the information provided is accurate.

Inspector Name: _____

Inspector Company: _____

Address: _____

Signature: _____ Date: _____

Page 3 of 3; version October 31, 2012

Sample Cut Sheets

SOLARMOUNT Technical Datasheets



SolarMount Technical Datasheet

Pub 110818-1td V1.0 August 2011

SolarMount Module Connection Hardware	1
Bottom Up Module Clip.....	1
Mid Clamp.....	2
End Clamp.....	2
SolarMount Beam Connection Hardware	3
L-Foot.....	3
SolarMount Beams	4

SolarMount Module Connection Hardware

SolarMount Bottom Up Module Clip Part No. 302000C

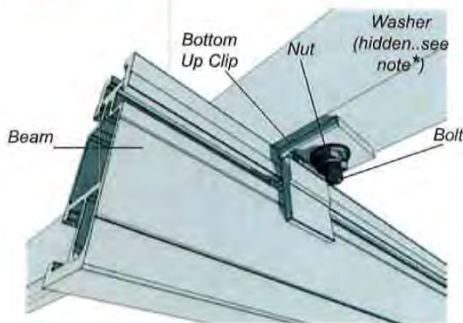

- **Bottom Up Clip material:** One of the following extruded aluminum alloys: 6005-T5, 6105-T5, 6061-T6
- **Ultimate tensile:** 38ksi, Yield: 35 ksi
- **Finish:** Clear Anodized
- **Bottom Up Clip weight:** ~0.031 lbs (14g)
- Allowable and design loads are valid when components are assembled with SolarMount series beams according to authorized UNIRAC documents
- Assemble with one 1/4"-20 ASTM F593 bolt, one 1/4"-20 ASTM F594 serrated flange nut, and one 1/4" flat washer
- Use anti-seize and tighten to 10 ft-lbs of torque
- Resistance factors and safety factors are determined according to part 1 section 9 of the 2005 Aluminum Design Manual and third-party test results from an IAS accredited laboratory
- Module edge must be fully supported by the beam
- * **NOTE ON WASHER:** Install washer on bolt head side of assembly. **DO NOT** install washer under serrated flange nut

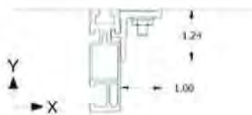

Dimensions specified in inches unless noted

Applied Load Direction	Average Ultimate lbs (N)	Allowable Load lbs (N)	Safety Factor, FS	Design Load lbs (N)	Resistance Factor, Φ
Tension, Y+	1566 (6967)	686 (3052)	2.28	1038 (4615)	0.662
Transverse, X±	1128 (5019)	329 (1463)	3.43	497 (2213)	0.441
Sliding, Z±	66 (292)	27 (119)	2.44	41 (181)	0.619



SolarMount Mid Clamp

Part No. 302101C, 302101D, 302103C, 302104D,
302105D, 302106D

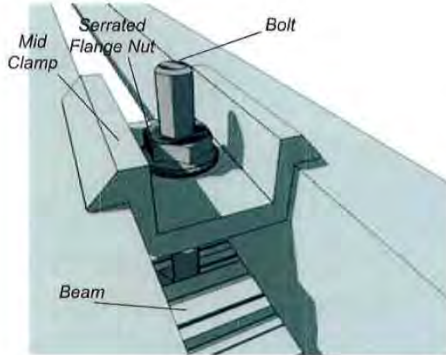

- **Mid clamp material:** One of the following extruded aluminum alloys: 6005-T5, 6105-T5, 6061-T6
- **Ultimate tensile:** 38ksi, Yield: 35 ksi
- **Finish:** Clear or Dark Anodized
- **Mid clamp weight:** 0.050 lbs (23g)
- Allowable and design loads are valid when components are assembled according to authorized UNIRAC documents
- Values represent the allowable and design load capacity of a single mid clamp assembly when used with a SolarMount series beam to retain a module in the direction indicated
- Assemble mid clamp with one Unirac ¼"-20 T-bolt and one ¼"-20 ASTM F594 serrated flange nut
- Use anti-seize and tighten to 10 ft-lbs of torque
- Resistance factors and safety factors are determined according to part 1 section 9 of the 2005 Aluminum Design Manual and third-party test results from an IAS accredited laboratory

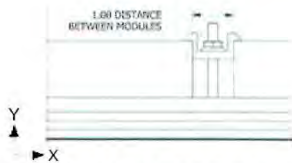

Dimensions specified in inches unless noted

Applied Load Direction	Average Ultimate lbs (N)	Allowable Load lbs (N)	Safety Factor, FS	Design Load lbs (N)	Resistance Factor, Φ
Tension, Y+	2020 (8987)	891 (3963)	2.27	1348 (5994)	0.667
Transverse, Z±	520 (2313)	229 (1017)	2.27	346 (1539)	0.665
Sliding, X±	1194 (5312)	490 (2179)	2.44	741 (3295)	0.620

SolarMount End Clamp

Part No. 302001C, 302002C, 302002D, 302003C,
302003D, 302004C, 302004D, 302005C, 302005D,
302006C, 302006D, 302007D, 302008C, 302008D,
302009C, 302009D, 302010C, 302011C, 302012C

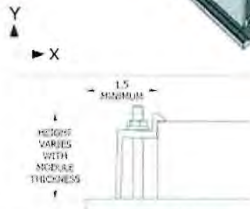
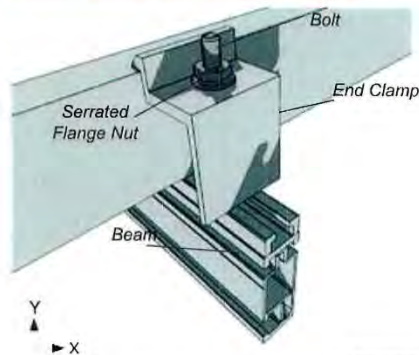

Dimensions specified in inches unless noted

- **End clamp material:** One of the following extruded aluminum alloys: 6005-T5, 6105-T5, 6061-T6
- **Ultimate tensile:** 38ksi, Yield: 35 ksi
- **Finish:** Clear or Dark Anodized
- **End clamp weight:** varies based on height: ~0.058 lbs (26g)
- Allowable and design loads are valid when components are assembled according to authorized UNIRAC documents
- Values represent the allowable and design load capacity of a single end clamp assembly when used with a SolarMount series beam to retain a module in the direction indicated
- Assemble with one Unirac ¼"-20 T-bolt and one ¼"-20 ASTM F594 serrated flange nut
- Use anti-seize and tighten to 10 ft-lbs of torque
- Resistance factors and safety factors are determined according to part 1 section 9 of the 2005 Aluminum Design Manual and third-party test results from an IAS accredited laboratory
- Modules must be installed at least 1.5 in from either end of a beam

Applied Load Direction	Average Ultimate lbs (N)	Allowable Load lbs (N)	Safety Factor, FS	Design Loads lbs (N)	Resistance Factor, Φ
Tension, Y+	1321 (5876)	529 (2352)	2.50	800 (3557)	0.605
Transverse, Z±	63 (279)	14 (61)	4.58	21 (92)	0.330
Sliding, X±	142 (630)	52 (231)	2.72	79 (349)	0.555

SolarMount Beam Connection Hardware

SolarMount L-Foot Part No. 304000C, 304000D

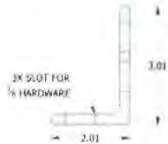
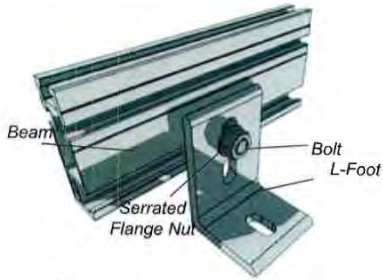

Dimensions specified in inches unless noted

- **L-Foot material:** One of the following extruded aluminum alloys: 6005-T5, 6105-T5, 6061-T6
- **Ultimate tensile:** 38ksi, Yield: 35 ksi
- **Finish:** Clear or Dark Anodized
- **L-Foot weight:** varies based on height: ~0.215 lbs (98g)
- Allowable and design loads are valid when components are assembled with SolarMount series beams according to authorized UNIRAC documents
- **For the beam to L-Foot connection:**
 - Assemble with one ASTM F593 3/8"-16 hex head screw and one ASTM F594 3/8" serrated flange nut
 - Use anti-seize and tighten to 30 ft-lbs of torque
- Resistance factors and safety factors are determined according to part 1 section 9 of the 2005 Aluminum Design Manual and third-party test results from an IAS accredited laboratory

NOTE: Loads are given for the L-Foot to beam connection only; be sure to check load limits for standoff, lag screw, or other attachment method

Applied Load Direction	Average Ultimate lbs (N)	Allowable Load lbs (N)	Safety Factor, FS	Design Load lbs (N)	Resistance Factor, ϕ
Sliding, Z \pm	1766 (7856)	755 (3356)	2.34	1141 (5077)	0.646
Tension, Y+	1859 (8269)	707 (3144)	2.63	1069 (4755)	0.575
Compression, Y-	3258 (14492)	1325 (5893)	2.46	2004 (8913)	0.615
Traverse, X \pm	486 (2162)	213 (949)	2.28	323 (1436)	0.664

SolarMount Beams

Part No. 310132C, 310132C-B, 310168C, 310168C-B, 310168D
 310208C, 310208C-B, 310240C, 310240C-B, 310240D,
 410144M, 410168M, 410204M, 410240M

Properties	Units	SolarMount	SolarMount HD
Beam Height	in	2.5	3.0
Approximate Weight (per linear ft)	plf	0.811	1.271
Total Cross Sectional Area	in ²	0.676	1.059
Section Modulus (X-Axis)	in ³	0.353	0.898
Section Modulus (Y-Axis)	in ³	0.113	0.221
Moment of Inertia (X-Axis)	in ⁴	0.464	1.450
Moment of Inertia (Y-Axis)	in ⁴	0.044	0.267
Radius of Gyration (X-Axis)	in	0.289	1.170
Radius of Gyration (Y-Axis)	in	0.254	0.502

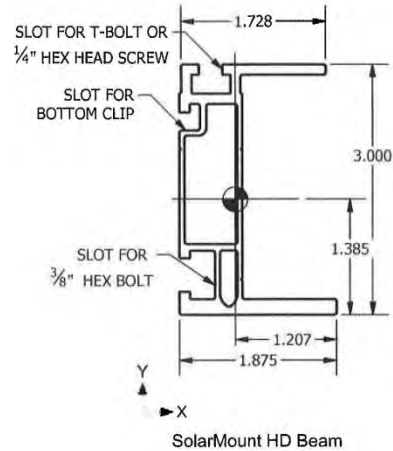
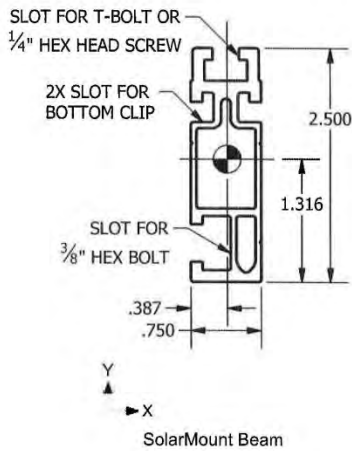

Dimensions specified in inches unless noted



NEW! 25-YEAR LINEAR PERFORMANCE GUARANTEE AND 5-YEAR EXTENDED PRODUCT WARRANTY*

Length 65.94 in (1675 mm)
 Width 39.41 in (1001 mm)
 Height 1.22 in (31 mm)
 Weight 46.7 lbs (21.2 kg)
 Frame Aluminum

Sunmodule⁺

SW 245 MONO

World-class quality

SolarWorld products are manufactured in state-of-the-art factories according to strict German and US quality standards.

Award-winning products

SolarWorld modules have been ranked number one for two years running in ongoing comparison tests carried out by the Photon trade magazine. Sunmodule plus panels generated up to 12% more yield than other major brand panels.

SolarWorld Plus-Sorting

Plus-Sorting guarantees the highest efficiency of the installation. SolarWorld only delivers modules that have greater than or equal to the nameplate rated power.

25-year Linear Performance Guarantee*

SolarWorld guarantees, over 25 years, that the modules' performance will not decrease by more than 0.7% per year – a distinct added value compared to industry-standard two-tiered guarantees.

*according to the SolarWorld service certificate valid at the time of purchase
www.solarworld-global.com/service-certificate



We turn sunlight into power.

www.solarworld-usa.com

Sunmodule⁺

SW 245 MONO

PERFORMANCE UNDER STANDARD TEST CONDITIONS (STC*)

SW 245		
Maximum power	P_{max}	245 Wp
Open circuit voltage	V_{oc}	37.7 V
Maximum power point voltage	V_{mpp}	30.8 V
Short-circuit current	I_{sc}	8.25 A
Maximum power point current	I_{mp}	7.96 A

*STC: 1000 W/m², 25°C, AM 1.5

PERFORMANCE AT 800 W/M², NOCT, AM 1.5

SW 245		
Maximum power	P_{max}	179 Wp
Open circuit voltage	V_{oc}	34.4 V
Maximum power point voltage	V_{mp}	28.1 V
Short-circuit current	I_{sc}	6.65 A
Maximum power point current	I_{mp}	6.37 A

Minor reduction in efficiency under partial load conditions at 25°C: at 220 W/m², 95% (+/- 3%) of the STC efficiency (1000 W/m²) is achieved.

COMPONENT MATERIALS

Cells per module	60
Cell type	Monocrystalline Silicon
Cell dimensions	156 mm x 156 mm
Front	tempered glass (EN12150)

SYSTEM INTEGRATION PARAMETERS

Maximum system voltage SC II	1000 V
Maximum system voltage USA NEC	600 V
Maximum reverse current	16 A
Increased snowload acc. to IEC 61215	5.4 kN/m ²

THERMAL CHARACTERISTICS

NOCT	47 °C
TC I_{sc}	0.042 %/°C
TC V_{oc}	-0.33 %/°C
TC P_{mpp}	-0.45 %/°C

ADDITIONAL DATA

Power tolerance ¹⁾	+/- 3%
SolarWorld Plus-Sorting ¹⁾	$P_{SW} \geq P_{max}$
Junction box	IP65
Connector	MC4
PTC rating	>19.6 W
Module efficiency	14.6%

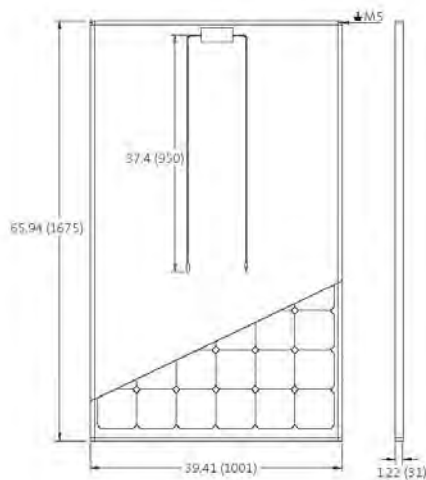

1) The output identified by Solar World (P_{SW}) is always higher than the nominal output (P_{max}) of the module.

SolarWorld AG reserves the right to make specification changes without notice. This data sheet complies with the requirements of EN 50380. Sunmodule panels are manufactured in ISO 9001:2000 certified facilities.



SUNNY BOY 5000US / 6000US / 7000US / 8000US

Profitable units with UL certification

Maximal energy yields for a continuously expanding solar market: the Sunny Boys with US certification are impressive due to their excellent efficiency. Additionally, they offer the highest degree of flexibility in plant design due to their graduated performance classes. The automatic grid voltage detection* allows easy and safe installation. Furthermore, the galvanic isolation provides flexible connection possibilities. This way, the Sunny Boy inverters can be used with crystalline cells, as well as with thin-film modules.

	Sunny Boy 5000-US	Sunny Boy 6000-US	Sunny Boy 7000-US	Sunny Boy 8000-US
	208 V AC 240 V AC 277 V AC	208 V AC 240 V AC 277 V AC	208 V AC 240 V AC 277 V AC	240 V AC 277 V AC
Input (DC)				
Max. recommended PV power (@ module STC)	6250 W	7500 W	8750 W	10000 W
Max. DC power (@ cos φ = 1)	5300 W	6350 W	7400 W	8600 W
Max. DC voltage	600 V	600 V	600 V	600 V
DC nominal voltage	310 V	310 V	310 V	345 V
MPP voltage range	250 V – 480 V	250 V – 480 V	250 V – 480 V	300 V – 480 V
Min. DC voltage / start voltage	250 V / 300 V	250 V / 300 V	250 V / 300 V	300 V / 365 V
Max. input current / per string (at DC disconnect)	21 A / 20 A, 36 A @ combined terminal	25 A / 20 A, 36 A @ combined terminal	30 A / 30 A, 36 A @ combined terminal	30 A / 20 A, 36 A @ combined terminal
Number of MPP trackers / fuse-protected strings per MPP tracker	1 / 4 (DC disconnect)	1 / 4 (DC disconnect)	1 / 4 (DC disconnect)	1 / 4 (DC disconnect)
Output (AC)				
AC nominal power	5000 W	6000 W	7000 W	7680 W 8000 W
Max. AC apparent power	5000 VA	6000 VA	7000 VA	8000 VA
Nominal AC voltage / adjustable	208 V / yes 240 V / yes 277 V / yes	208 V / yes 240 V / yes 277 V / yes	208 V / yes 240 V / yes 277 V / yes	240 V / yes 277 V / yes
AC voltage range	183 – 229 V 211 – 264 V 244 – 305 V	183 – 229 V 211 – 264 V 244 – 305 V	183 – 229 V 211 – 264 V 244 – 305 V	211 – 264 V 244 – 305 V
AC grid frequency, range	60 Hz; 59.3 – 60.5 Hz	60 Hz; 59.3 – 60.5 Hz	60 Hz; 59.3 – 60.5 Hz	60 Hz; 59.3 – 60.5 Hz
Max. output current	34 A 21 A 16 A	29 A 25 A 22 A	34 A 29 A 25 A	32 A
Power factor (cos φ)	1	1	1	1
Phase conductors / connection phases	1 / 2 1 / 2 1 / 1	1 / 2 1 / 2 1 / 1	1 / 2 1 / 2 1 / 1	1 / 2 1 / 1
Harmonics	< 4 %	< 4 %	< 4 %	< 4 %
Efficiency				
Max. efficiency	96.7 % 96.8 % 96.8 %	96.9 % 96.8 % 97.0 %	97.1 % 96.9 % 97.0 %	96.3 % 96.5 %
CEC efficiency	95.5 % 95.5 % 95.5 %	95.5 % 95.5 % 96.0 %	95.5 % 96.0 % 96.0 %	96.0 % 96.0 %
Protection devices				
DC reverse-polarity protection	yes	yes	yes	yes
AC short-circuit protection	yes	yes	yes	yes
Galvanically isolated / all-pole sensitive monitoring unit	yes / –	yes / –	yes / –	yes / –
Protection class / overvoltage category	I / III	I / III	I / III	I / III
General data				
Dimensions (W / H / D) in mm (in)	470 / 615 / 240 (18.4 / 24.1 / 9.5)	470 / 615 / 240 (18.4 / 24.1 / 9.5)	470 / 615 / 240 (18.4 / 24.1 / 9.5)	470 / 615 / 240 (18.4 / 24.1 / 9.5)
DC Disconnect dimensions (W / H / D)	167 / 297 / 190	187 / 297 / 190	187 / 297 / 190	187 / 297 / 190

in mm (in)	(7.3 / 11.7 / 7)	(7.3 / 11.7 / 7)	(7.3 / 11.7 / 7)	(7.3 / 11.7 / 7)
Packing dimensions (W / H / D) in mm (in)	390 / 580 / 800 (31 / 15 / 23)	390 / 580 / 800 (31 / 15 / 23)	390 / 580 / 800 (31 / 15 / 23)	390 / 580 / 800 (31 / 15 / 23)
DC Disconnect packing dimensions (W / H / D) in mm (in)	580 / 400 / 270 (23 / 16 / 11)	580 / 400 / 270 (23 / 16 / 11)	580 / 400 / 270 (23 / 16 / 11)	580 / 400 / 270 (23 / 16 / 11)
Weight / DC Disconnect weight	64 kg (143 lb) / 3.5 kg (8 lb)	64 kg (143 lb) / 3.5 kg (8 lb)	64 kg (143 lb) / 3.5 kg (8 lb)	66 kg (148 lb) / 3.5 kg (8 lb)
Packing weight / DC Disconnect packing weight	67 kg (148 lb) / 4 kg (9 lb)	67 kg (148 lb) / 4 kg (9 lb)	67 kg (148 lb) / 4 kg (9 lb)	69 kg (152 lb) / 4 kg (9 lb)
Operating temperature range (full power)	-25 °C ... +45 ° C / -13 °F ... +113 °F	-25 °C ... +45 ° C / -13 °F ... +113 °F	-25 °C ... +45 ° C / -13 °F ... +113 °F	-25 °C ... +45 ° C / -13 °F ... +113 °F
Noise emission (typical)	44 dB(A)	45 dB(A)	46 dB(A)	49 dB(A)
Internal consumption: (night)	0.1 W	0.1 W	0.1 W	0.1 W
Topology	LF transformer	LF transformer	LF transformer	LF transformer
Cooling concept	OptiCool	OptiCool	OptiCool	OptiCool
Electronics protection rating / connection area	NEMA 3R / NEMA 3R	NEMA 3R / NEMA 3R	NEMA 3R / NEMA 3R	NEMA 3R / NEMA 3R

Features

Display: text line / graphic	yes /—	yes /—	yes /—	yes /—
Interfaces: RS485 / Bluetooth	opt. / opt.	opt. / opt.	opt. / opt.	opt. / opt.
Warranty: 10 / 15 / 20 years	yes / opt. / opt.	yes / opt. / opt.	yes / opt. / opt.	yes / opt. / opt.
Certificates and permits (more available on request)	UL1741, UL1998, IEEE 1547, FCC Part 15 (Class A & B)	UL1741, UL1998, IEEE 1547, FCC Part 15 (Class A & B)	UL1741, UL1998, IEEE 1547, FCC Part 15 (Class A & B)	UL1741, UL1998, IEEE 1547, FCC Part 15 (Class A & B)
Data at nominal conditions				
Type designation	SB 5000US	SB 6000US	SB 7000US	SB 8000US

Home > Products > Grid-Tied Inverters > SUNNY BOY > SUNNY BOY 5000US / 6000US / 7000US / 8000US

SUNNY BOY 5000US / 6000US / 7000US / 8000US
SUNNY BOY 3000-US / 4000-US
SUNNY BOY 2000H-US / 2500H-US / 3000H-US
SUNNY BOY 700-US
COMBI-SWITCH

2010 | Press | Legal Notice | Terms and Conditions | SMA Feed



Solar Access

Related to the installation of small scale solar PV systems is the right to solar access, which involves a property owner's right to access to all available direct solar light without shading from structures or vegetation on surround properties. This issue is not addressed in this initiative or analysis.

Residential and small scale solar installations are much more prevalent in central and western states (i.e. Colorado, Arizona, and California) and ordinances protecting solar access there are more common. Municipalities in Western Pennsylvania that have tried to implement ordinances protecting solar access have encountered significant obstacles.

More than half of the states in the U.S. authorize the creation of solar easements. The majority of solar easement statutes stipulate that any instrument creating such an agreement must contain the following elements:

The vertical and horizontal angles, expressed in degrees, at which the solar easement extends over the real property subject to the solar easement. Some states allow for any other description which defines the three-dimensional space, or the place and time of day in which an obstruction to direct sunlight is prohibited or limited.

Any terms or conditions, or both, under which the solar easement is granted or will be terminated.

- Any provisions for compensation of the owner of the property benefiting from the solar easement in the event of interference with the enjoyment of the solar easement or compensation of the owner of the property subject to the solar easement for maintaining the solar easement.

Solar Rights and Solar Easements

The solar access issue is separated into two distinct areas: solar easements and solar rights.

“Solar easements” refers to the ability of one property to continue to receive sunlight across property lines without obstruction from another’s property (e.g., buildings, foliage, or other impediments). “Solar rights” refers to the ability to install solar energy systems on residential and commercial property that is subject to private restrictions (e.g., covenants, conditions, restrictions, bylaws, condominium declarations, and local government ordinances and building codes).

The United States has held that there is no common law right to sunlight. This requires that specific statutory authority be established to protect the rights of solar users in terms of their ability to install a solar energy system on their property, and after that system is installed, to protect their access to sunlight so the system remains operational.

Other common components include:

- A description of the property subject to the easement (servient property) and a description of the property benefitting from the solar easement (dominant property).
- Definitions of the solar energy devices, systems, or structural design features whose access to sunlight is covered under the solar easement law. Specifying the types of solar energy devices the statute is designed to promote is essential. For example, are clotheslines considered a solar energy device? Are passive solar buildings protected or only active solar electric and solar thermal collectors? Only about 10 states provide a definition of solar energy device, collector or system.

Such agreements must be in writing and are subject to the same recording and indexing requirements as other instruments affecting the title to real property. Solar energy system owners may need to compensate a neighboring party in order to secure solar access rights, although such easements are typically transferred with the property title and do not terminate unless specified by conditions of the easement. In general, state laws that allow for voluntary solar easements may have limited effectiveness since solar energy system owners have no guarantee of an agreement with a neighbor whose property could interfere with access to sunlight.

Solar and Historic Properties

Historic and cultural resources that meet a set of criteria may be listed in three types of registers: the National Register of Historic Places, a state register of historic places, or local register of historic landmarks and districts. The type of designation is the key consideration in the application of preservation guidelines and regulations.

Most relevant to the installation of solar PV on historic properties is preservation at the local level. Pennsylvania municipalities may create historic districts to protect the historic character through regulation of the reconstruction, alteration, restoration or demolition of buildings in the district. Local ordinances can establish Historic Architectural Review Boards (HARBs) or other preservation commissions that provide an advisory or regulatory role. Some commissions have adopted design guidelines for historic districts. They may be recommendations or may be enforced through design review boards that approve or deny proposed alterations to a property based on the design review guidelines.

There are established cases where historic buildings have successfully retained listing on the National Register of Historic Places with the introduction of solar PV systems through careful coordination with the State

Preservation Standards and Solar

The Secretary of the Interior has established standards for the preservation and protection of cultural resources. The standards are intended to promote responsible preservation practices that help protect the nation's cultural resources. Of the Secretary's ten Standards for Rehabilitation, three are particularly relevant to solar PV projects:

1. Standard 2: the historic character of a property will be retained and preserved.
2. Standard 9: new additions, exterior alterations, or related new construction will not destroy historic materials, features, and spatial relationships that characterize the property. The new work shall be differentiated from the old and will be compatible with the historic materials, features, size, scale and proportion, and massing to protect the integrity of the property and its environment.
3. Standard 10: new additions and adjacent or related new construction will be undertaken in such a manner that, if removed in the future, the essential form and integrity of the historic property and its environment would be unimpaired.

Historic Preservation Office (SHPO). Further, Pennsylvania has an established legal framework for the regulation and preservation of historic resources at the state and local level.

Solar PV ordinances should require that owners of historic properties or properties within historic districts work with the appropriate review board or SHPO before obtaining final zoning/permitting approval of a proposed solar PV installation from the municipality. Of the ordinances and permit applications reviewed, one permit application specified the need to comply with any architectural or historic design standards or review board restrictions. The applicant should first approach the appropriate office for preliminary zoning approval for the proposed solar PV installation on a historic structure or a structure in a historic district. The applicant will then meet with the HARB or other design review board. Upon approval of a design solution, final zoning approval and review will complete the application process for a proposed solar PV installation. Solutions identified through the design review process cannot preempt zoning or other ordinance regulations. This same process could be used where any design review is required.